



UPOMPE UTO SERIES THERMAL OIL PUMP

DESIGN FEATURES

Single stage, horizontal volute pumps series UTO have been specially developed for handling no solid grain weak corrosive high temperature liquid, such as mineral oil and synthetic heat carriers up to 350°C in the heat engineering industry. The increased demands on operational safety, environmental protection and the reduction in running expenses have consequently been considered in this design. Casing and stuffing box cover as pressure loaded components and frame adaptor are made of ductile iron.

With the combination effects of carbon sleeve bearing restricts oil to seal area, ribs on stuffing box cover aid in the dissipation of heat, and throttling clearance behind the hydraulics, a favorable drop in temperature in the shaft seal area is achieved, with heat losses of the product handled are effectively prevented i.e. energy is being saved. This enables the safe use of a simple uncooled type of shaft sealing. Since heat carriers possess anything but good lubricating properties, a liquid-flushed carbon sleeve bearing next to the impeller and an antifriction bearing next behind the mechanical seal, and thus not being wetted by the heat carrier, have been fitted. Through this arrangement, noiseless operation and long service lives have been achieved.

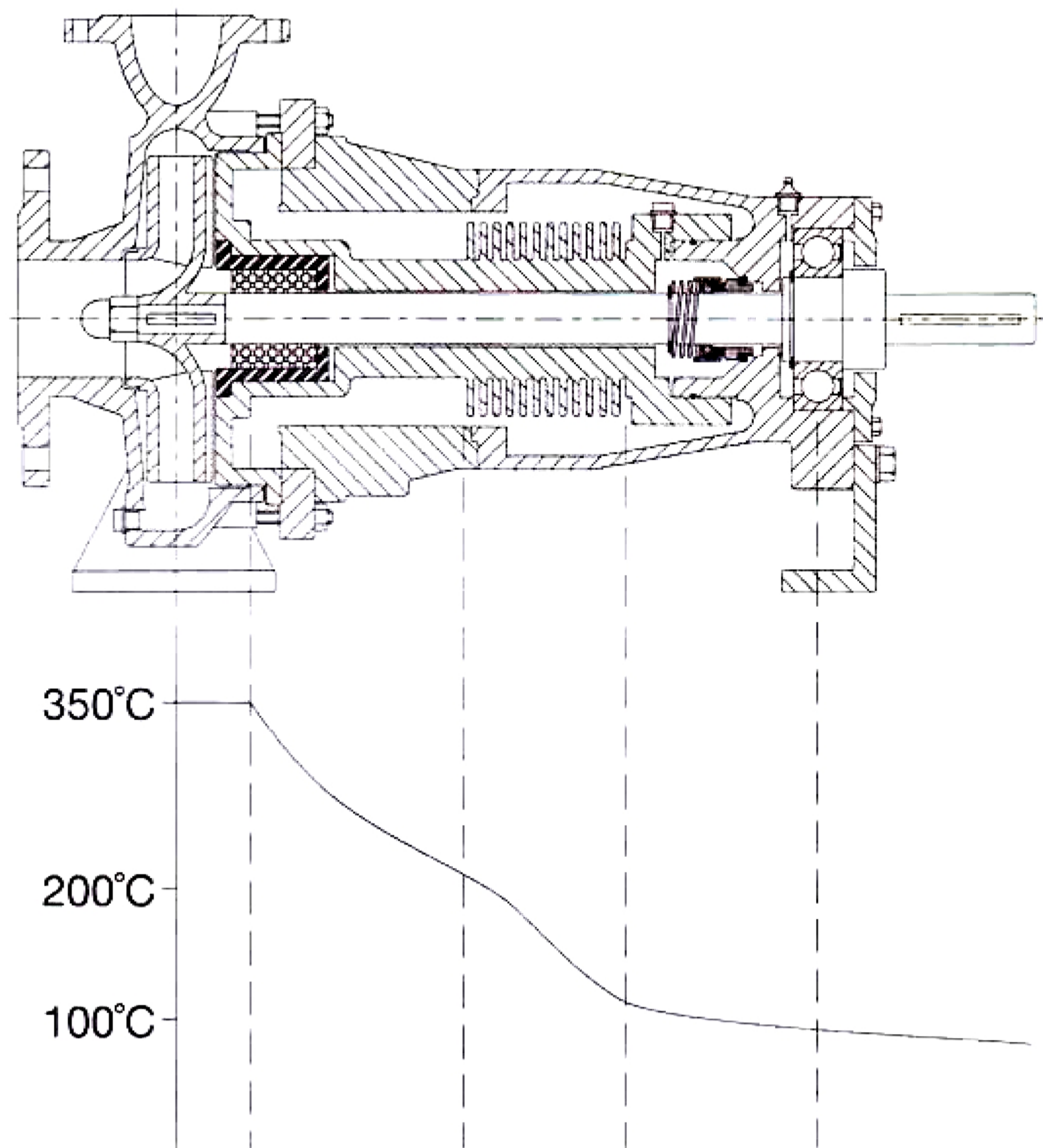

APPLICATION

These pumps can be used in installation with positive or negative suction. The most important cases of application are to be found in plants in chemical industry, rubber and plastic industry, food industry, paper industry, and laundries.

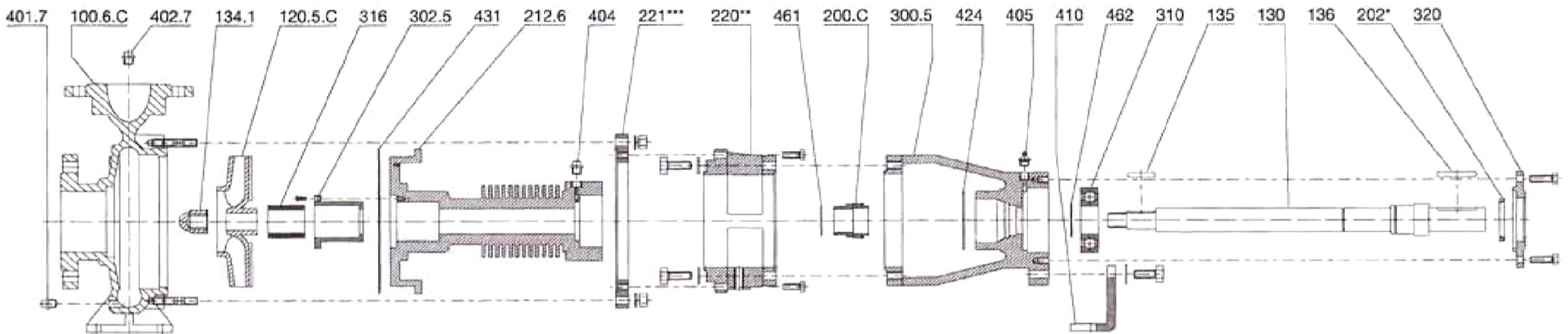

Part No.	Description	Standard Material
100.6.C	Casing for Closed Impeller	Ductile Iron
120.5.C	Closed Impeller	Cast Iron
130	Shaft	Stainless Steel 304
134.1	Impeller Nut	Stainless Steel 304
135	Key for Impeller	Stainless Steel 304
136	Shaft End Key	Stainless Steel 304
200.C	Mechanical Seal	Carbon vs. SiC
202*	V-Seal	Synthetic Rubber
212.6	Stuffing Box Cover	Ductile Iron
220**	Frame Adaptor	Ductile Iron
221***	Adaptor Extension Ring	Cast Iron
300.5	Bearing Frame	Cast Iron
302.5	Sleeve Bearing Housing	Cast Iron
310	Bearing	Steel

Part No.	Description	Standard Material
316	Sleeve Bearing	Synthetic Carbon
320	Bearing Cover	Cast Iron
401.7	Casing Drain Plug	Galvanise Steel
402.7	Venting Plug	Galvanise Steel
404	Oil Plug	Galvanise Steel
405	Grease Nipple	Steel
410	Support Foot	Cast Iron
424	Bearing Frame "O" Ring	Synthetic Rubber
431	Stuffing Box Cover Gasket	P.T.F.E.
461	Mechanical Seal Cir Clip	Steel
462	Bearing Cir Clip	Steel

* For models 100-260 and 125-260 only.

** For all applicable models except 32-160, 40-160, 50-160, 32-200, 40-200 and 50-200.

*** For all applicable models except 32-160, 40-160, 50-160, 65-160 and 80-160.

GENERAL DIMENSIONS

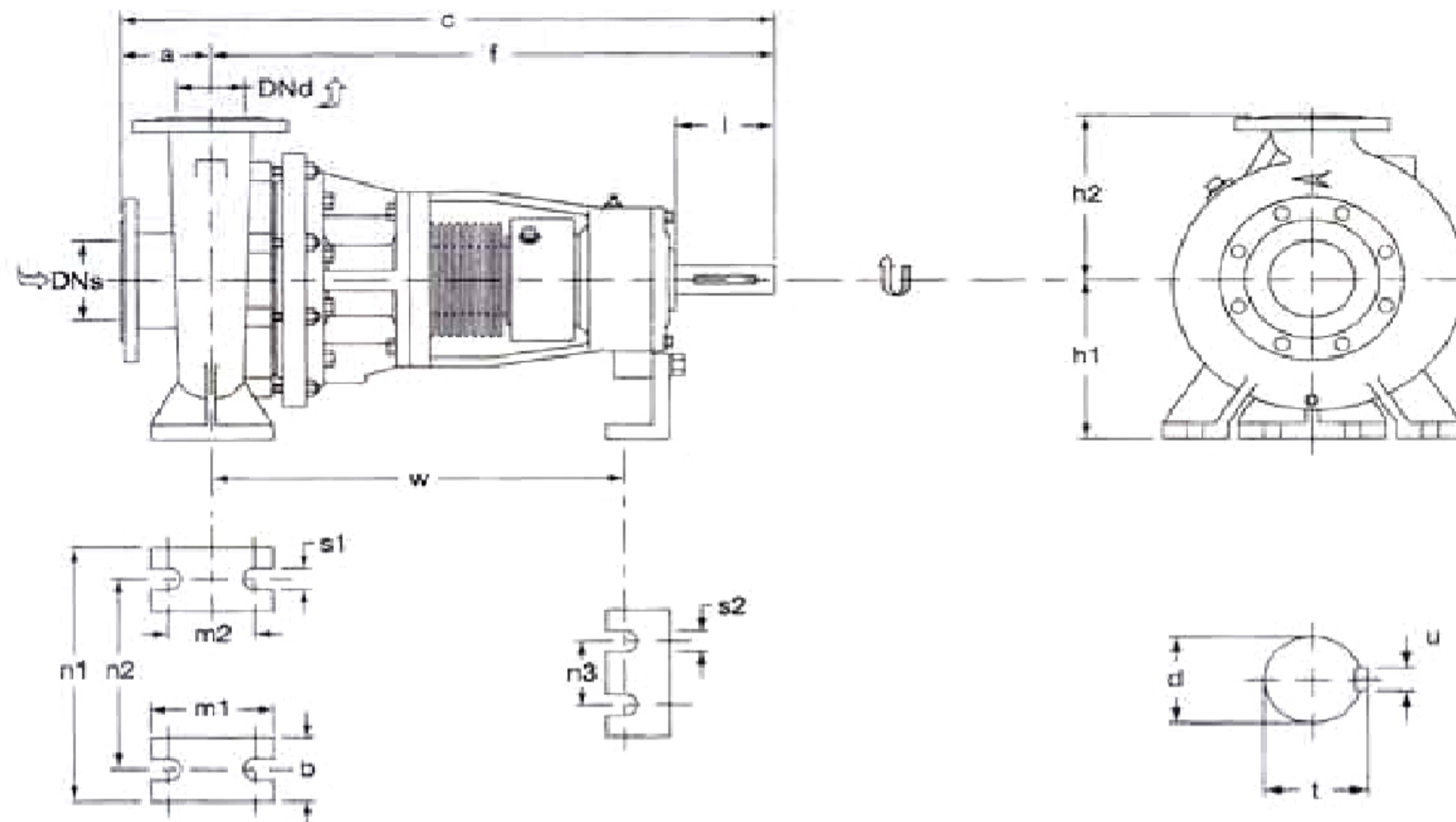

PUMP MODEL	Flanges		Pump Dimensions					Foot Dimensions							Shaft End															
	DNd	DNs	a	f	c	h1	h2	b	m1	m2	n1	n2	n3	s1	s2	w	d	l	t	u										
32-160	32	50	80	385	465	132	160	50	100	70	240	190	110	14	14	285	24	50	27.9	8										
32-200			100	500	600	180	225														65	125	95	320	250	370	32	80	35.3	10
32-260			100	500	600	180	225														65	125	95	320	250	370	32	80	35.3	10
40-160	40	65	80	385	465	132	160	50	100	70	240	190	110	14	14	285	24	50	27.9	8										
40-200			100	500	600	180	225														65	125	95	265	212	370	32	80	35.3	10
40-260			100	500	600	180	225														65	125	95	320	250	370	32	80	35.3	10
50-160	50	80	100	385	485	160	180	50	100	70	265	212	110	14	14	285	24	50	27.9	8										
50-200			100	500	600	180	225														65	125	95	320	250	370	32	80	35.3	10
50-260			125	500	625	180	225														65	125	95	320	250	370	32	80	35.3	10
65-160	65	100	100	500	600	160	200	65	125	95	280	212	110	14	14	370	32	80	35.3	10										
65-200			100	500	600	180	225														65	125	95	320	250	370	32	80	35.3	10
65-260			125	500	625	200	250														80	160	120	360	280	370	32	80	35.3	10
80-160	80	125	125	500	625	180	225	65	125	95	320	250	110	14	14	370	32	80	35.3	10										
80-200			125	500	625	180	250														65	125	95	345	280	370	32	80	35.3	10
80-260 ²⁾			140	500	625	200	280														80	160	120	400	315	370	32	80	35.3	10
100-200	100	125	125	500	625	200	280	80	160	120	360	280	110	14	14	370	32	80	35.3	10										
100-260 ¹⁾			140	530	670	225	280														80	160	120	400	315	370	42	95	45.1	12
125-200	125	150	140	500	640	250	315	80	160	120	400	315	110	14	14	370	32	80	35.3	10										
125-260 ¹⁾			140	530	670	250	355														80	160	120	400	315	370	42	95	45.1	12

¹⁾ In these models the dimension "l" is 15mm shorter than the specified in ISO 2858. The dimension "f" is according to ISO 2858

²⁾ In this model the dimension "h1" is 25mm smaller than the specified in ISO 2858

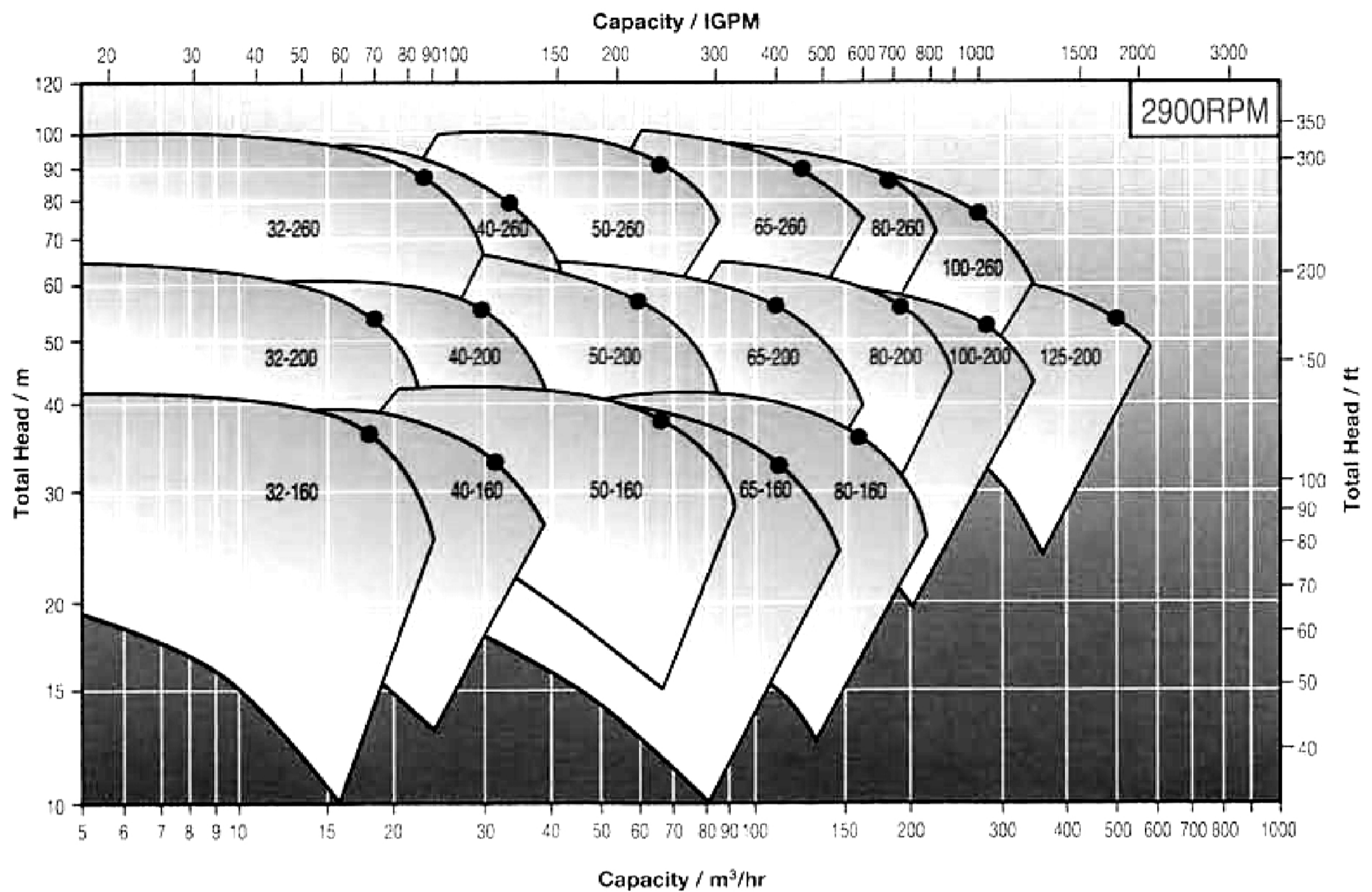
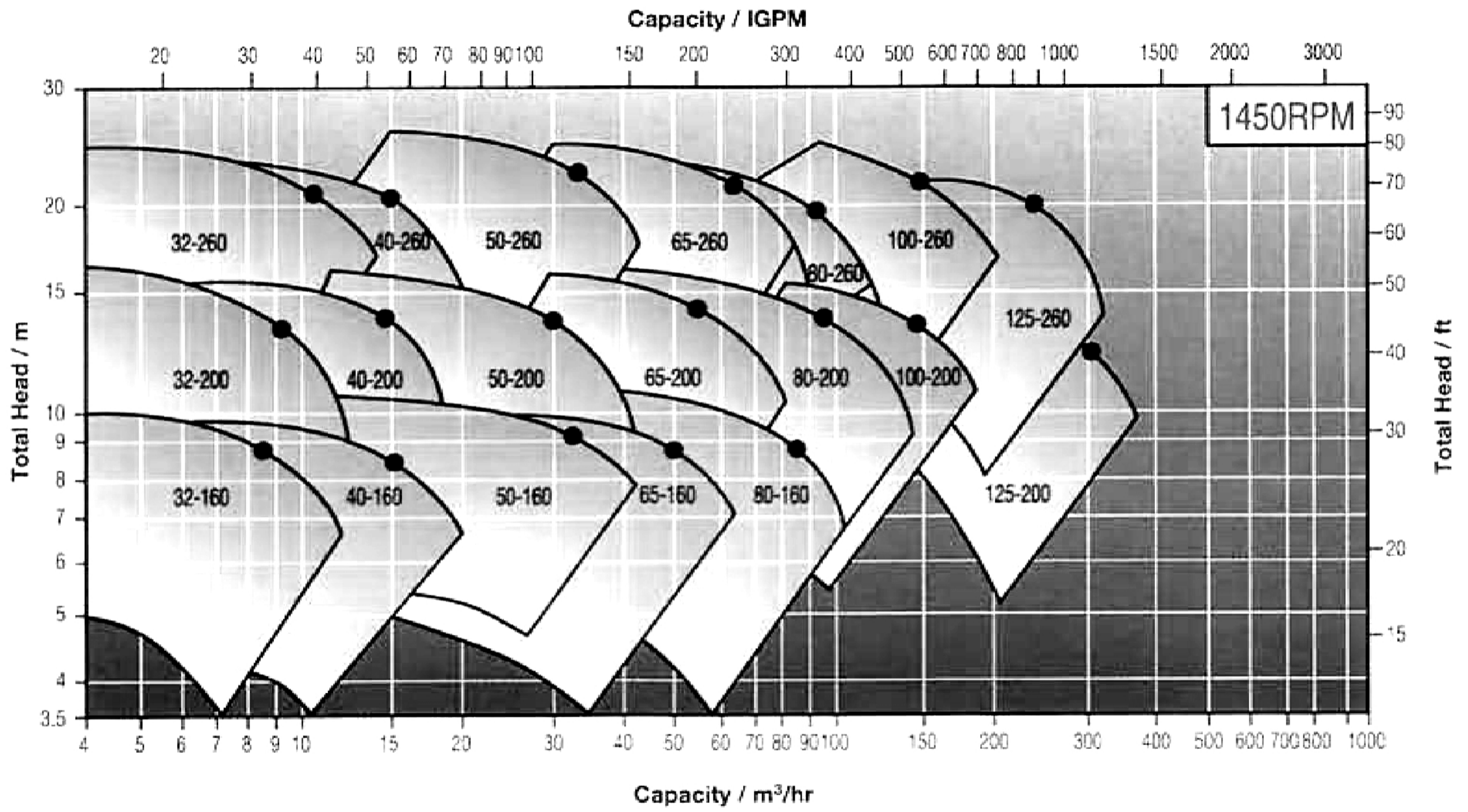

Curve for reference only. For final selection refer to individual pump curve.
 Black dots on curves show best efficiency points.