

PTM-AP • FLOOR MOUNTING SINGLE SPRING ISOLATOR
PTM-AM • HEAVY LOADING MULTIPLE SPRING ISOLATOR

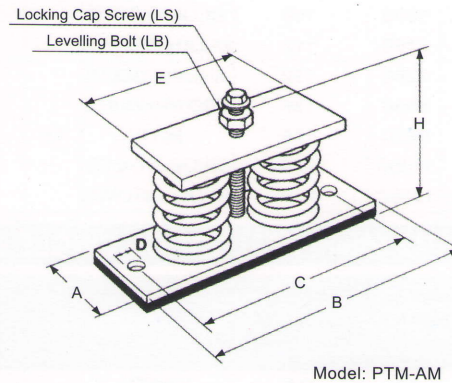
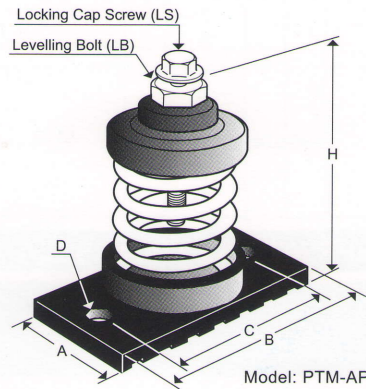

TOZEN Model PTM-AP is a series of unboxed spring vibration isolators consist of high deflection, laterally stable steel springs assembled with a levelling device at the top and non-skid acoustical pad at the bottom. Model PTM-AP employs moulded rubber upper and lower holding cup with built in levelling feature and a mounting plate base to allow for bolting the isolators to the structure. Model PTM-AM are multiple spring isolator for heavy loading applications.

APPLICATION

PTM-AP series spring isolators are typically used to reduce the transmission of noise and vibration from low speed mechanical equipments into a building structure. PTM-AP series spring isolators are used in a wide range of applications, such as, reciprocating air or refrigeration compressors, close coupled and base mounted pumps, package air handling and refrigeration equipments, centrifugal fans, internal combustion engines and similar equipments.

PTM-AP 25mm DEFLECTION SINGLE SPRING VIBRATION ISOLATOR

(mm)

Model	Rated Capacity		Spring Constant (Kg/mm)	Spring Element			Operating Height (H)	(A)	(B)	(C)	(D)	(E)	Locking Cap Screw (LS)	Levelling Bolt (LB)
	(Kgs)	(Lbs)		Colour Code	O.D	Free Height								
PTM-AP-10S	10	22	0.4	GREEN	50	80	120	64	120	90	10	-	M10	M16
PTM-AP-15S	15	33	0.6	BLUE										
PTM-AP-25S	25	55	1	WHITE										
PTM-AP-35S	35	77	1.4	YELLOW										
PTM-AP-50S	50	110	2	ORANGE										
PTM-AP-80S	80	176	3.2	PURPLE(PINK)										
PTM-AP-120S	120	264	4.8	RED										
PTM-AP-175ES	175	385	7	SILVER										
PTM-AP-225ES	225	495	9	BROWN										
PTM-AP-150M	150	330	6	ORANGE	75	100	160	92	150	120	12	-	M12	M22
PTM-AP-200M	200	440	8	PURPLE(PINK)										
PTM-AP-300M	300	660	12	RED										
PTM-AP-450M	450	990	18	GREEN										
PTM-AP-600EM	600	1320	24	SILVER										
PTM-AP-825EM	825	1815	33	BROWN(GOLD)										
PTM-AP-975EM	975	2145	39	BROWN+WHITE										
PTM-AP-1100EM	1100	2420	44	BLUE										
PTM-AP-1250EM	1250	2750	50	BLUE+WHITE										
PTM-AP-1400EM	1400	3080	56	BLUE+BROWN										

PTM-AM 25mm DEFLECTION MULTIPLE SPRING VIBRATION ISOLATOR

(mm)

Model	Rated Capacity		Spring Constant (Kg/mm)	Spring Element			Operating Height (H)	(A)	(B)	(C)	(D)	(E)	Locking Cap Screw (LS)	Levelling Bolt (LB)
	(Kgs)	(Lbs)		Colour code	O.D	Free Height								
PTM-AM-1652EM	1650	3630	66	BROWN(GOLD)	75	100	160	85	285	245	16	220	M12	M22
PTM-AM-1952EM	1950	4290	78	BROWN+WHITE										
PTM-AM-2202EM	2200	4840	88	BLUE										
PTM-AM-2502EM	2500	5500	100	BLUE+WHITE										
PTM-AM-2802EM	2800	6160	112	BLUE+BROWN										
PTM-AM-3304EM	3300	7260	132	BROWN(GOLD)	75	100	165	190	255	190	16	190	M16	M30
PTM-AM-3904EM	3900	8580	156	BROWN+WHITE										
PTM-AM-4404EM	4400	9680	176	BLUE										
PTM-AM-5004EM	5000	11000	200	BLUE+WHITE										
PTM-AM-5604EM	5600	12320	224	BLUE+BROWN										

PTM-AP2 & PTM-AM2 50mm DEFLECTION SINGLE & MULTIPLE SPRING VIBRATION ISOLATOR

(mm)

Model	Rated Capacity		Spring Constant (Kg/mm)	Spring Element			Operating Height (H)	(A)	(B)	(C)	(D)	(E)	Locking Cap Screw (LS)	Levelling Bolt (LB)
	(Kgs)	(Lbs)		Colour code	O.D	Free Height								
PTM-AP2-25S	25	55	0.5	WHITE	75	120	180	92	150	120	12	-	M12	M22
PTM-AP2-35S	35	77	0.7	YELLOW										
PTM-AP2-50S	50	110	1	ORANGE										
PTM-AP2-80ES	80	176	1.6	PURPLE(PINK)										
PTM-AP2-125ES	125	275	2.5	RED										
PTM-AP2-175ES	175	385	3.5	SILVER										
PTM-AP2-250ES	250	550	5	BROWN(GOLD)										
PTM-AP2-175EM	175	385	3.5	ORANGE	90	145	200	106	160	130	14	-	M12	M22
PTM-AP2-245EM	245	539	4.9	PURPLE(PINK)										
PTM-AP2-350EM	350	770	7	RED										
PTM-AP2-525EM	525	1155	10.5	GREEN										
PTM-AP2-750EM	750	1650	15	SILVER										
PTM-AP2-1050EM	1050	2310	21	SILVER+BROWN										
PTM-AM2-1502EM	1500	3300	30	SILVER										
PTM-AM2-2102EM	2100	4620	42	SILVER+BROWN										
PTM-AM2-3004EM	3000	6600	60	SILVER										
PTM-AM2-4204EM	4200	9240	84	SILVER+BROWN										

PTM-AP3 & PTM-AM3 75mm DEFLECTION SINGLE & MULTIPLE SPRING VIBRATION ISOLATOR

(mm)

Model	Rated Capacity		Spring Constant (Kg/mm)	Spring Element			Operating Height (H)	(A)	(B)	(C)	(D)	(E)	Locking Cap Screw (LS)	Levelling Bolt (LB)
	(Kgs)	(Lbs)		Colour code	O.D	Free Height								
PTM-AP3-80ES	80	176	1.07	WHITE	90	170	220	100	170	140	14	-	M12	M22
PTM-AP3-125ES	125	275	1.67	YELLOW										
PTM-AP3-180ES	180	396	2.4	ORANGE										
PTM-AP3-255ES	255	561	3.4	PURPLE(PINK)										
PTM-AP3-375ES	375	825	5	RED										
PTM-AP3-555EL	555	1221	7.4	PURPLE(PINK)	110	190	250	125	195	165	14	-	M12	M22
PTM-AP3-810EL	810	1782	10.8	RED										
PTM-AP3-1065EL	1065	2343	14.2	RED+BROWN										
PTM-AM3-1112EL	1110	2442	14.8	PURPLE(PINK)	110	190	255	125	360	330	16	295	M12	M22
PTM-AM3-1622EL	1620	3564	21.6	RED										
PTM-AM3-2132EL	2130	4686	28.4	RED+BROWN										
PTM-AM3-2224EL	2220	4884	29.6	PURPLE(PINK)	110	190	260	290	335	295	16	265	M16	M30
PTM-AM3-3244EL	3240	7128	43.2	RED										
PTM-AM3-4264EL	4260	9372	56.8	RED+BROWN										

Note:

- All springs are free standing and laterally stable. (Outside diameter shall not less than 0.8 times of compressed height)
- All springs are designed to provide additional travel to solid of at least 50% rated load.
- Please refer to relevant brochure or contact our sales department for greater deflection and loading.

Specifications are subject to change without prior notice.