



Axial and mixed flow pumps for
high volume water handling

Customised solutions!

Grundfos is prepared to offer you a solution in handling large amounts of water from a wide range of submersible axial flow propeller pumps and mixed flow pumps depending on the demands with a motor range from 15 kW up to 1000 kW

Whatever you choose, your pump will be optimised for your specific task.



Engineered to suit your application

Every KPL and KWM pump is individually engineered to suit your requirements, ensuring cost-efficient performance. For the best results, contact us during your planning stages – that allows us to consider aspects such as pumping station design, pump selection, future requirements, and the total Life Cycle Costs.

Reliability meets excellent value

- Quality products
- Robust, reliable and cost-effective
- Maximum value for money



Minimal, easy service

- Simple pump design ensures lasting trouble-free operation
- All pumps are individually tested and registered, so the right spare parts can be supplied very efficiently. Even after many years.



Wide choice

- All models available in cast iron or stainless steel
- 50 or 60 Hz
- Special materials (e.g. aluminium bronze propellers) available on request
- High voltage (up to 6600 volts by special request) models available
- Pump and motor size up to 1000 kW by special request

Large flows handled with ease

KPL and KWM pumps are designed for extremely large flows at relatively low head. The range covers:

- Flows up to 11,700 l/s
- Heads up to 20 m

Features and benefits

- 1. Reliability**
One-piece molded type cable entry with triple compression sealing and anti-wicking block that ensures water-tightness
- 2. High Efficiency**
Heavy duty, insulation class F (H as an option), air-filled (oil-filled as an option) with IP 68 protection motor ensures efficient and low-cost operation.
- 3. Customer-oriented**
Wear-resistant propellers with adjustable vanes machined precisely to maintain exact tolerances for maximum hydraulic efficiency, and dynamically balanced to avoid vibration.
- 4. Easy to install and maintain**
Bumper ring around guide casing secures easy installation and removal. Simple and compact rotation stopper that prevents from tilting and guarantees fast installation
- 5. Checks on everything**
Pumps are always a part of a bigger picture. By incorporating sensors in the KPL and KWM, we make sure that the pumps perform their part reliably - they warn you of potential problems so that you take appropriate measures in due time.



Performance overview

KPL Axial Flow Pumps

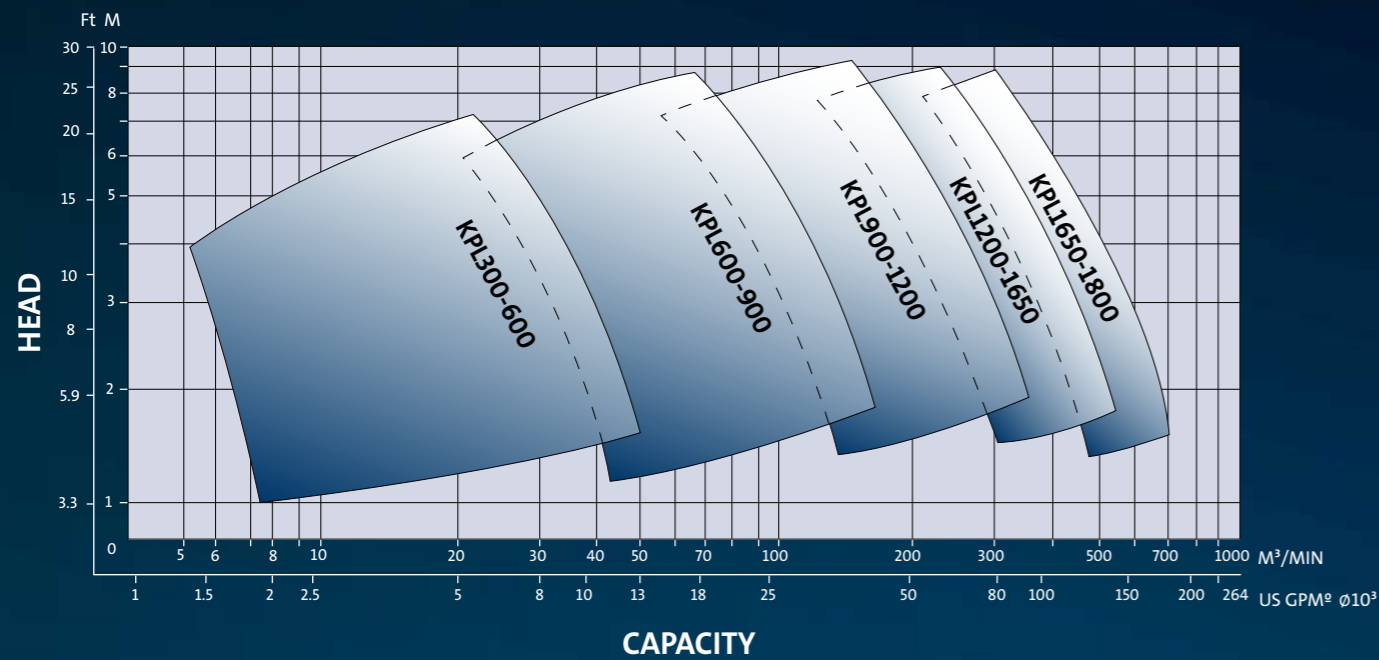

*Number after model name states the discharge diameter (mm).

Material specification						
Part	Description	Material	DIN / EN	ASTM / AISI	BS	JIS
Top cover		Cast iron	EN-JL1040	A48-30	1425-77, 180	FC200
Stator housing		Cast iron	EN-JL1040	A48-30	1425-77, 180	FC200
Pump housing		Cast iron	EN-JL1040	A48-30	1425-77, 180	FC200
Cable entry		Cast iron	EN-JL1040	A48-30	1425-77, 180	FC200
Wear ring		Cast iron	EN-JL1040	A48-30	1425-77, 180	FC200
Propeller hub	KPL	Cast iron	EN-JL1040	A48-30	1425-77, 180	FC200
Propeller vane		Alu bronze	EN-CC333G	AB148-958	1400-70, AB2	AIBC3
Propeller cap		Cast iron	EN-JL1040	A48-30	1425-77, 180	FC200
Impeller	KWM	Cast iron	EN-JL1040	A48-30	1425-77, 180	FC200
Pump shaft		Stainless steel	W.-nr 1.4400	410	970-70, 410S21	SUS410
Bolts and nuts		Stainless steel	W.-nr 1.4301	304	970-70, 304S15	SUS304
O-rings						
Bearings	Heavy-duty prelubricated ball bearings	Stainless steel				
Primary shaft seal		SiC/SiC				
Secondary shaft seal		SiC/SiC				
O-rings in shaft seal	Nitril rubber	NBR				
Lifting bracket		Cast iron	EN-JL1040	A48-30	1425-77, 180	FC200
Cable types	Power cable (AA x BB mm²)					
	Sensor cable (AA x BB mm²)					
Surface protection	2 layer Epoxy coating. Colour: Black					

KWM Mixed Flow Pumps

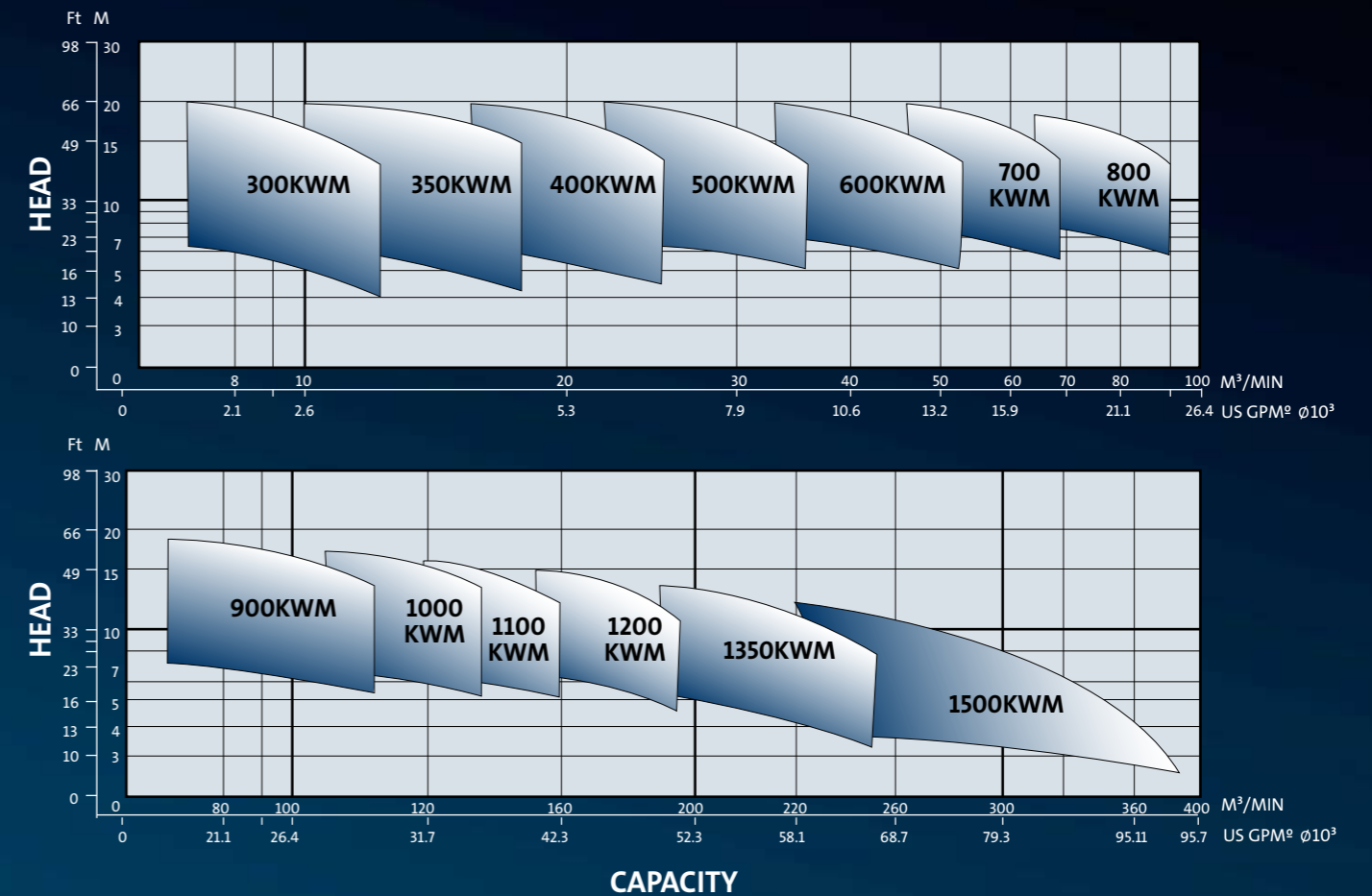

*Number before model name states the discharge diameter (mm).

OPERATING CONDITIONS

	Standard	On request
Maximum starting requency	10 starts/hour	10 starts/hour
Maximum ambient temperature	40°C	40°C
Maximum liquid temperature	40°C	40°C
Storage temperature	(-30 to +60°C)	(-30 to +60°C)
Maximumm submergence	20m	20m
Voltage version	all 50Hz	all 50Hz
	all 60Hz	all 60Hz
Insulation class	Class F	High voltage Class H
Mechanical shaft seal	SiC/SiC	TC/TC or WC/WC

Inside the KPL and KWM ...

Trouble-free junction box

Water-tight enclosed connection chamber with IP 68 protection. Cable inlet with strain-relief, anti-kink device and double seal.

Durable motor

Trouble-free, low-cost operation is ensured by the air-filled squirrel-cage induction motor – which includes thermal protection embedded in each phase. From 4 to 18 poles designed for class S1 duty. NEMA Design B, Class F insulation windings as standard. (Explosion-proof version also available: Class1, Div. 1, Groups C&D).

Oil chamber gives added safety

Oil-filled chamber lubricates and cools mechanical seal units – and provides an additional leakage barrier.

KPL propeller

The KPL features a pump bowl equipped with diffuser vanes and an axial propeller. The wear-resistant impellers are precision-machined to ensure exact tolerances for maximum hydraulic efficiency – and dynamically balanced to avoid vibration. Adjustable pitch propeller also available.

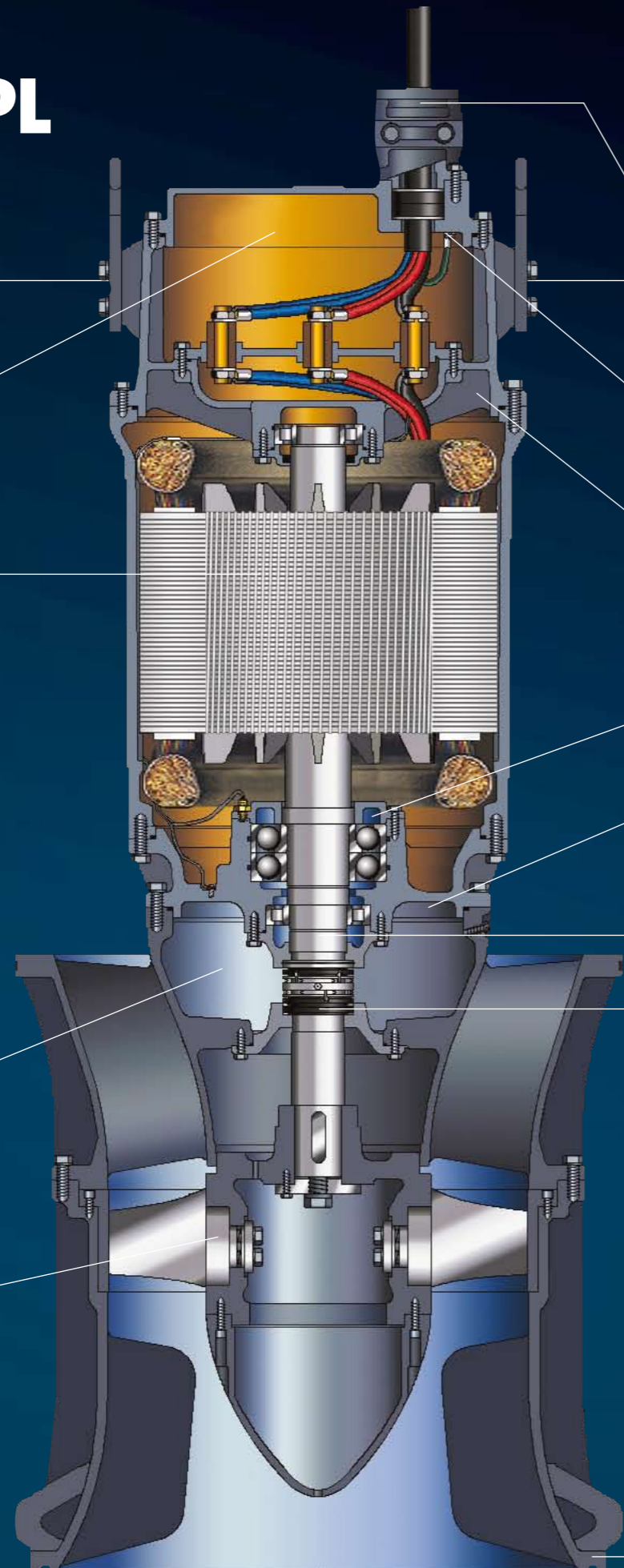

The submersible KPL propeller pumps and KWM mixed flow pumps combine quality elements inside a compact design.

Despite their power, they require little space and are easily installed – allowing you to drastically reduce your construction costs.

Water-tight cable entry

Leaks are prevented by this single-piece, moulded cable entry point with triple compression sealing and anti-wicking block.

Sensors maximise protection

Depending on motor size, each pump incorporates sensors for maximum protection at reasonable cost. Your choice includes sensors to monitor winding temperature, seal condition, moisture, water-in-oil, and bearing temperature.

Shaft and bearings for smooth, long-term operation

Enjoy smooth, vibration-free operation thanks to the oversized stainless-steel shaft and oversized ball-type thrust and radial bearings. The maintenance-free antifriction bearings have built-in permanent grease lubrication. Minimum 100,000 hours of bearing life (L-10 Life).

Mechanical seals prolong pump life

The double mechanical shaft seal, mounted in an oil chamber with an additional lip seal, ensures long life even in the most demanding conditions.

Rotation stopper for easy handling

Simple, compact rotation stopper prevents the pump from tilting and ensures fast installation and removal.



KPL Propeller

The KPL version is equipped with an axial flow propeller



KWM impeller

The KWM version is equipped with a multi-channelled impeller.

Choose the installation set-up that suits you

With the Grundfos KPL and KWM, installation has the same scope for customisation as the pumps themselves. Installed directly in the column pipe, KPL and KWM pumps seriously reduce the need for construction works – so they can even save you money before they prove their efficiency in day-to-day operation.

Choose between different installation types.

Ask us for installation recommendations. We can often help you create a more efficient, more durable system.

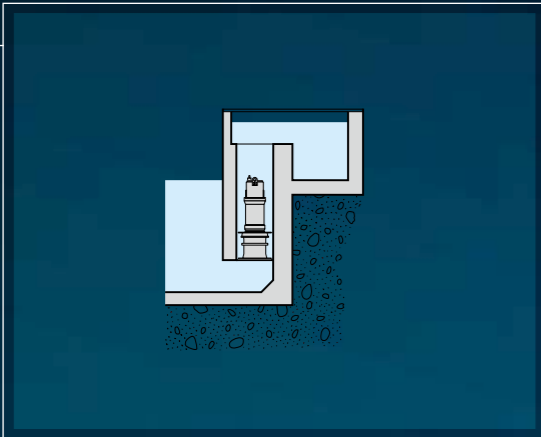

Suitable where the liquid is pumped to a tunnel, channel or basin with a water level that is nearly constant so that shut-off devices are not required. This arrangement involves the smallest number of steel components; it consists of a circular concrete tube and a short pipe grouted in place as a base for the pump. Because the top of the tube is placed at a level slightly above the maximum water level in the outlet channel, water cannot run back to the sump when the pump is shut off.

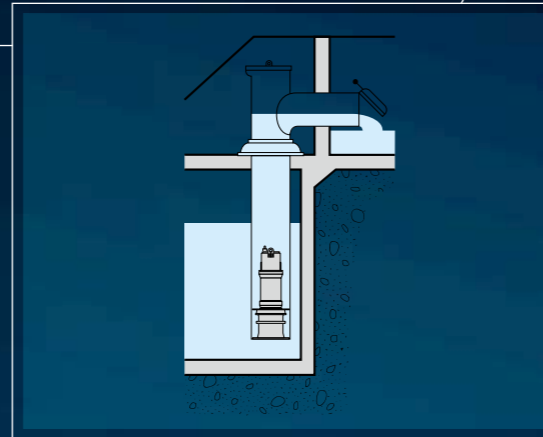

If the water level on the outlet side of the pump varies considerably, flap valves can be installed. Normally the pump works against the head in the discharge channel or basin; when the pump is not in operation, the water is prevented from running back to the sump by the automatic closure of the valve. In this way, the pump always operates against the minimum head.

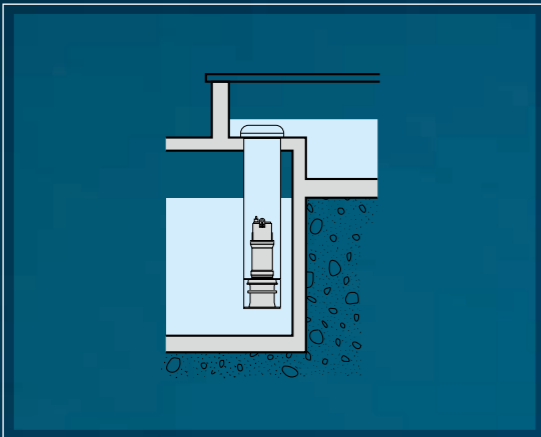

In this case the pump is placed in a suspended steel column with a collar that rests on a supporting frame.

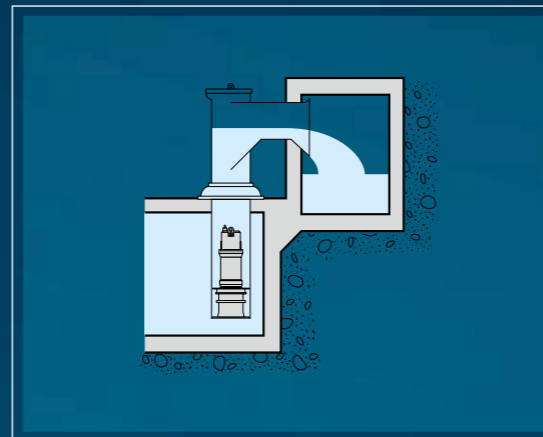

If odors require a closed system, this arrangement can be used with a free discharge, as shown, in order to prevent from water backflash.

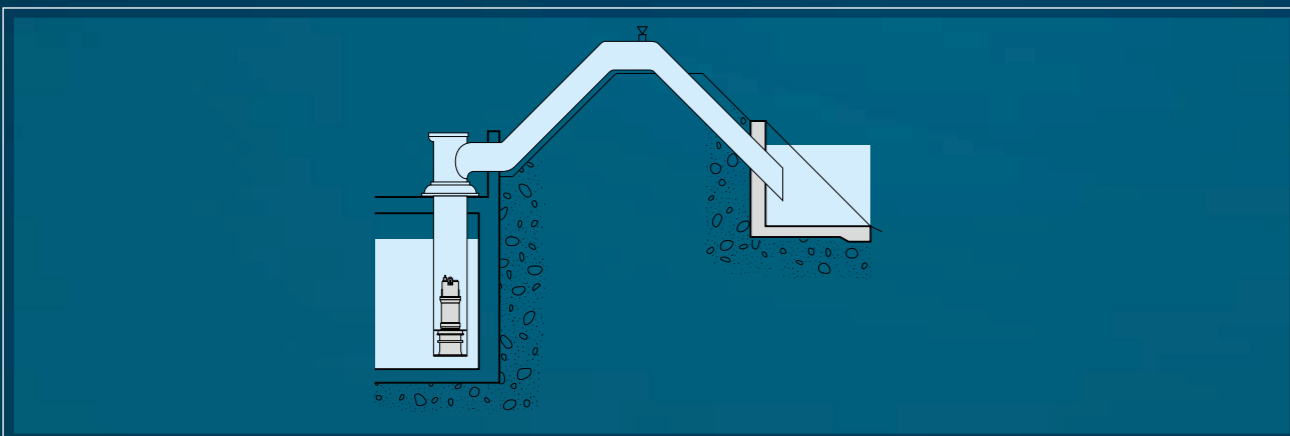

If the pump is to work in combination with a siphon or a discharge line, a pressure-tight discharge elbow must be used. The elbow recommended here permits both fast installation and easy retrieval of the pumps.

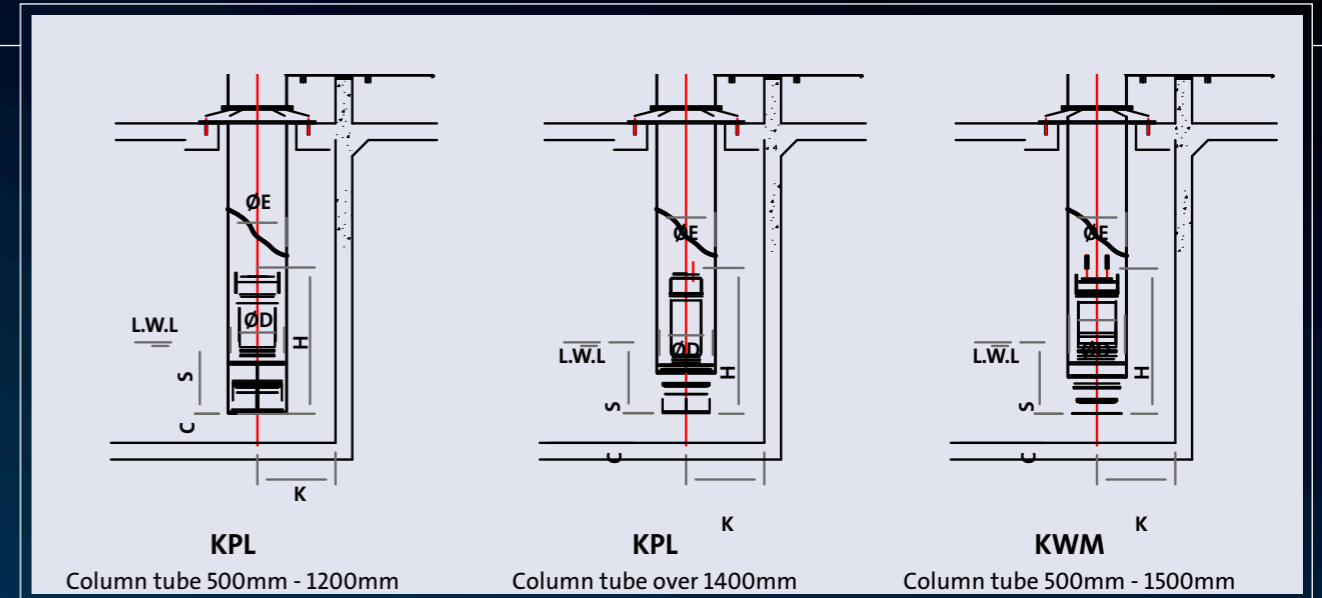

KPL – 50Hz & 60Hz/Dimensions & weight

Product	ØE	D	H	S	C	K	Weight
KPL 500	500	403	1000 - 1200	600 - 800	250	500	350 - 600
KPL 600	600	560	1250 - 1650	900 - 1100	300	1200	500 - 1200
KPL 700	700	670	1765 - 2150	1200 - 1400	350	1400	700 - 2000
KPL 800	800	750	1950 - 2200	1375 - 1500	400	1600	1200 - 2500
KPL 900	900	860	2100 - 2350	1495 - 1620	450	1800	1500 - 2000
KPL 1000	1000	930 - 980	2350 - 2600	1620 - 1765	500	2000	1700 - 2700
KPL 1100	1100	1070	2600 - 2730	1710 - 1845	550	2200	2200 - 3200
KPL 1200	1200	1160	2880 - 3050	1973 - 2158	600	2400	2000 - 4500
KPL 1400	1400	1360	3070 - 3500	1600 - 2325	700	2800	3000 - 5000
KPL 1600	1600	1400 - 1420	3600 - 4800	2500 - 3110	800	3200	3500 - 7000

KWM – 50Hz & 60Hz/Dimensions & weight

Product	ØE	D	H	S	C	K	Weight
KWM 500	500	420	1100 - 1300	700 - 800	250	500	400 - 600
KWM 600	600	540	1400 - 1700	900 - 1100	300	600	800 - 1100
KWM 700	700	670	1500 - 2100	900 - 1300	350	700	1000 - 1500
KWM 800	800	770	2000 - 2400	1300 - 1500	400	800	1400 - 2000
KWM 1000	1000	940	2200 - 2500	1400 - 1600	500	1000	2000 - 2800
KWM 1100	1100	1060	2800 - 3100	1800 - 1900	550	1100	2800 - 3100
KWM 1200	1200	1165	2900 - 3300	1900 - 2100	600	1200	3000 - 4200
KWM 1300	1300	1250	3200 - 3600	2100 - 2300	650	1300	3800 - 4500
KWM 1500	1600	1460	3400 - 3800	2200 - 2500	750	1500	4100 - 7500

Applications

Suitable for many different tasks

Built to handle large quantities of raw water, the pumps are ideal for a wide range of applications.

- Flood and storm water control
- Large-volume drainage and irrigation
- Raw water intake
- Circulation of large quantities of water, e.g. in water parks
- Water-level control in coastal and low-lying areas
- Filling and emptying of dry docks and harbour installations
- Filling or emptying of reservoirs
- Treated sewage
- Cooling water intake in power stations
- Process and discharge water
- - and other low to medium head/high flow applications



Flood control pumping station



Irrigation



Drydocks



Waste Water Treatment Plant

GRUNDFOS KPL-KWM ranges in Drydocks World - Dubai

One of the biggest pump installations of marine application in the Middle East

Dubai, United Arab Emirates

Drydocks World – Dubai, is located on the Dubai Waterfront and is one of the largest shipyards in the world. The shipyard employs nearly 10,000 workers and over 1000 subcontractors. More than 5000 vessels and oilrigs have been repaired and maintained at the facility, since it opened in 1983.

The situation

As a part of their extensive yard development initiative, which included creating new facilities for new shipbuilding and offshore modules fabrication, Drydocks World – Dubai (Client) launched the SAFINA PROJECT, a “Hydrolift” ship launching and recovery facility. The Hydrolift facility requires pumping of seawater to raise levels from mean sea level to the impounding level of +9.5 m CD within four hours. The Client specified four new pumps with a normal duty of 2.2 m³/sec at 10m head with free passage to allow 40 mm size particles.

Drydocks World – Dubai specified that each pump be supplied with its own power and control cables for termination at the top of each pump’s venting tube. The client would then install a connection box and small console at the top of each venting tube. Four umbilical’s will then run from the four connection boxes to the east abutment and into the control panel. The pumps were specified to be capable of being started (or re-started) and establish symphonic discharge conditions for which the symphonic loop invert level is +10.00, from any level between Highest Astronomical Tide (HAT) and Lowest Astronomical Tide (LAT).

The Grundfos solution

Grundfos was chosen, after series of technical-commercial evaluations, due to low life cycle cost, high level of competence, extensive technical knowledge, short delivery time and continuous support available in the U.A.E.

The flexibility of the Grundfos engineering team and product range were also major advantages that contributed favourably in comparison to other interested parties.



Grundfos was commissioned to supply 4 units of KWM Mixed Flow Impeller Pumps with 300kW motors. The pumps were installed in chambers (1200 mm dia.) on the seaward face of the new East Abutment. Mr. Rajesh Kumar, Projects Manager, Grundfos Gulf Distribution, quoted “As per tender design the pumps would have been subjected to cavitations, due to siphoning effect, as the discharge end of the pipe was located below the sea level. Based on Grundfos’ suggestions (accepted by consultant), the client modified the discharge pipe level. Another challenge was that the client had the soft starter installed in their facility and we had to carry out minor cable modifications to suit it. This was successfully executed by our Grundfos service team at the site, before the pumps were installed”.

“We are satisfied with the performance of the Grundfos pumps as well as the pre-sales and post-sales support rendered to us continuously by Grundfos engineers. The pumps have been operating successfully for almost 3 years now,” said Mr. Murtaza Rampuri, Manager-Yard Development Department, Drydocks World -Dubai.

The client, with the help of Grundfos service department, carry out the scheduled periodic maintenance checks to ensure that the pumps are kept in good condition.

Finally, Drydocks World - Dubai also awarded Grundfos the contract for supply of SCUTTLE DEWATERING PUMPS, which are used in the Hydrolift Main Gate ballasting operations.

SEE THE BIGGER PICTURE

Grundfos is a global leader within water handling technology. Our passion is to bring you all the products you require to create and operate pump systems that combine reliability, cost-efficiency – and innovation. Our products are for use in water supply and wastewater infrastructure on any scale.

Grundfos has a full line of products and systems for the intake, treatment and distribution of drinking water and for the transport and treatment of wastewater. We also offer expertise and industry insight that can increase reliability and reduce lifecycle costs for water utilities.

Key product areas include:

-  Submersible pumps
-  Surface pumps
-  Sewage pumps
-  Mixers, flowmakers & recirculation pumps
-  Pumping stations
-  Monitoring & controls
-  Dosing & disinfection
-  Aeration equipment

Our products are the result of decades of engineering expertise. Supported by a worldwide service network. Visit www.grundfos.com/water-utility for more.