

SECTION B CONTENTS

THREE PIECE BALL VALVES

DESCRIPTION	PAGE
82-100 Series, Threaded Full Port Bronze	B-1
82-200 Series, Solder Full Port Bronze	B-2
83R-100 Series, Actuator Ready Threaded Full Port Carbon Steel	B-3
83R-200 Series, Actuator Ready Socket Weld Full Port Carbon Steel	B-4
83R-700 Series, Actuator Ready Butt-Weld Full Port Carbon Steel	B-5
85R-100 Series, Actuator Ready Threaded Stainless Steel	B-6
85R-200 Series, Actuator Ready Socket Weld Stainless Steel	B-7
86R-100 Series, Actuator Ready Threaded Full Port Stainless Steel	B-8
86R-200 Series, Actuator Ready Socket Weld Full Port Stainless Steel	B-9
86R-700 Series, Actuator Ready Butt-Weld Full Port Stainless Steel	B-10
401R-100 Series, Actuator Ready Threaded Full Port Alloy 20	B-11
401R-200 Series, Actuator Ready Socket Weld Full Port Alloy 20	B-12
83-300 Series, Threaded High Pressure Carbon Steel	B-13
83-400 Series, Socket Weld High Pressure Carbon Steel	B-14
83-500 Series, Threaded Full Port High Pressure Carbon Steel	B-15
83-600 Series, Socket Weld Full Port High Pressure Carbon Steel	B-16
85-100 Series, Threaded Stainless Steel	B-17
85-200 Series, Socket Weld Stainless Steel	B-18
86-500 Series, Threaded Full Port High Pressure Stainless Steel	B-19
86-600 Series, Socket Weld Full Port High Pressure Stainless Steel	B-20
86-900 Series, Butt-Weld Full Port High Pressure Stainless Steel	B-21

Apollo® 82-100 Series Bronze 3-Piece Full Port Ball Valve

Threaded, 600 psig WOG, Cold Non-Shock. 150 psig Saturated Steam.
Vacuum Service to 29 inches Hg.
Federal Specification: WW-V-35C, Type: II, Composition: BZ, Style: 1.
MSS SP-110; Ball Valve Threaded, Socket-Welding, Solder Joint, Grooved and Flared Ends.

FEATURES

- Full port configuration
- RPTFE seats and seals
- In-line repairable
- Blow-out-proof stem design
- Adjustable packing gland

STANDARD MATERIAL LIST

1. Lever and grip	Steel, zinc plated w/vinyl	10. Body bolt	Steel, zinc plated
2. Stem packing	RPTFE	11. Hex nut	Steel, zinc plated
3. Stem bearing	RPTFE	12. Body	B584-C84400
4. Ball	B16, chrome plated (except 3" & 4")		
5. Seat (2)	RPTFE		
6. End cap (2)	B16 (1/4" to 3/8") B584-C84400 (1/2" to 4")		
7. Gland nut	B16		
8. Stem	B16 (except 3" & 4")		
9. Lever nut	Steel, zinc plated		

VARIATIONS AVAILABLE:

82-140 Series (316 SS Ball & Stem)

82-150 Series (Original Balancing Stop)

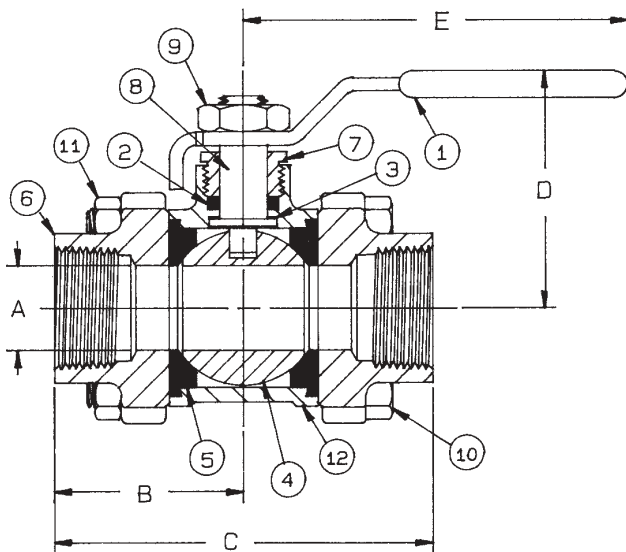

BRONZE 3-PIECE FULL PORT BALL VALVE

NUMBER	SIZE	A	B	C	D	E	Wt.
82-101-01	1/4"	.43	1.28	2.56	1.81	3.87	1.02
82-102-01	3/8"	.50	1.28	2.56	1.81	3.87	1.04
82-103-01	1/2"	.62	1.40	2.81	1.93	4.87	1.55
82-104-01	3/4"	.81	1.71	3.43	2.18	4.87	2.27
82-105-01	1"	1.00	1.93	3.87	2.62	5.50	3.28
82-106-01	1-1/4"	1.25	2.37	4.75	2.87	5.50	5.62
82-107-01	1-1/2"	1.50	2.62	5.25	3.37	8.00	8.07
82-108-01	2"	2.00	3.01	6.03	3.68	8.00	14.42
82-109-01	2-1/2"	2.50	3.62	7.25	5.14	9.75	26.61
82-140-01	3"	3.00	4.00	8.00	6.77	18.00	42.24
82-14A-01	4"	4.00	5.50	11.00	8.26	18.00	88.40

OPTIONS AVAILABLE:

(SUFFIX)	OPTION	SIZES
-02-	Static Grounded	1/4" to 4"
-03-	1-1/4" Stem Extension	1/4" to 2"
-04-	2-1/4" Stem Extension	1/4" to 2"
-05-	Plain Ball	1/4" to 4"
-07-	Tee Handle	1/4" to 2"
-08-	90° Reversed Stem	1/4" to 4"
-10-	SS Lever & Nut	1/4" to 4"
-14-	Vented Ball (see page J-2)	1/4" to 4"
-15-	Round Handle	1/4" to 2"
-16-	Vertical Chain Lever	1/2" to 2"
-18-	Plain Yellow Grip	1/4" to 2"
-19-	Lock Plate	1/4" to 4"
-20-	Slot Vented Ball	1/4" to 4"
-21-	UHMWPE Seats	1/4" to 4"
-23-	Tank Flange	2" ONLY
-24-	Graphite Stem Packing	1/4" to 4"
-27-	Latch Lock Lever	1/2" to 2"
-30-	CamLock Handle	1/4" to 1-1/4"
-32-	SS Tee Handle & Nut	1/4" to 2"
-35-	PTFE Trim	1/4" to 4"
-39-	SS Hi-Rise Locking Wheel Handle, SS Nut	1/4" to 1-1/4"
-40-	Cyl-Loc & Grounded	1/4" to 1/2"
-45-	Less Lever & Nut	1/4" to 4"
-46-	Latch-Lock Lever - Lock in Closed Position Only	1/2" to 2"
-47-	SS Oval Latch-Lock Handle & Nut	1/4" to 3/4"
-48-	SS Oval Handle (No Latch) & Nut	1/4" to 2"
-49-	Assembled Dry	1/4" to 4"
-50-	2-1/4" CS Locking Stem Extension	1/4" to 2"
-56-	Multifill Seats & Graphite Packing	1/4" - 4"
-57-	Oxygen Cleaned	1/4" to 4"
-58-	Chain Lever - Horizontal	1/2" to 2"
-59-	SS External Trim - 3-pc. Valves	1/4" to 4"
-60-	Grounded Ball & Stem	1/4" to 4"
-63-	NPT x Solder/Socket Weld	3/8" to 4"
-P01-	BSPP (Parallel) Thread Connection	1/4" to 4"
-T01-	BSPT (Tapered) Thread Connection	1/4" to 4"

**For Pressure/Temperature Ratings,
Refer to Page M-8, Graph No. 4**

Bronze 3-Piece Full Port Solder End Ball Valve

Solder End, 600 psig WOG, Cold Non-Shock. 150 psig Saturated Steam.
Vacuum Service to 29 inches Hg.

Federal Specification: WW-V-35B, Type: II, Composition: BZ, Style: 1.

Designed For Soft Solder or Brazed Installation.

MSS SP-110; Ball Valve Threaded, Socket-Welding, Solder Joint, Grooved and Flared Ends.

FEATURES

- Full port configuration
- RPTFE seats and seals
- In-line repairable
- Blow-out-proof stem design
- Adjustable packing gland

STANDARD MATERIAL LIST

1. Lever and grip	Steel, zinc plated w/vinyl	10. Body bolt	Steel, zinc plated
2. Stem packing	RPTFE	11. Hex nut	Steel, zinc plated
3. Stem bearing	RPTFE	12. Body	B584-C84400
4. Ball	B16, chrome plated (except 3" & 4")		
5. Seat (2)	RPTFE		
6. End cap (2)	B16 (3/8")		
	B584-C84400 (1/2" to 4")		
7. Gland nut	B16		
8. Stem	B16 (except 3" & 4")		
9. Lever nut	Steel, zinc plated		

OPTIONS AVAILABLE:

(SUFFIX)	OPTION	SIZES
-02-	Static Grounded	3/8" to 4"
-03-	1-1/4" Stem Extension	3/8" to 2"
-04-	2-1/4" Stem Extension	3/8" to 2"
-05-	Plain Ball	3/8" to 4"
-07-	Tee Handle	3/8" to 2"
-08-	90° Reversed Stem	3/8" to 4"
-10-	SS Lever & Nut	3/8" to 4"
-14-	Vented Ball (see page J-2)	3/8" to 4"
-15-	Round Handle	3/8" to 2"
-16-	Vertical Chain Lever	1/2" to 2"
-18-	Plain Yellow Grip	3/8" to 2"
-19-	Lock Plate	3/8" to 4"
-20-	Slot Vented Ball	3/8" to 4"
-21-	UHMWPE Seats	3/8" to 4"
-23-	Tank Flange	2" ONLY
-24-	Graphite Stem Packing	3/8" to 4"
-27-	Latch Lock Lever	1/2" to 2"
-30-	CamLock Handle	3/8" to 1-1/4"
-32-	SS Tee Handle & Nut	3/8" to 2"
-35-	VTFE Trim	3/8" to 4"
-39-	SS Hi-Rise Locking Wheel Handle, SS Nut	3/8" to 1-1/4"
-40-	Cyl-Loc & Grounded	3/8" to 1/2"
-45-	Less Lever & Nut	3/8" to 4"
-46-	Latch-Lock Lever - Lock in Closed Position Only	1/2" to 2"
-47-	SS Oval Latch-Lock Handle & Nut	3/8" to 3/4"
-48-	SS Oval Handle (No Latch) & Nut	1/4" to 2"
-49-	Assembled Dry	3/8" to 4"
-50-	2-1/4" CS Locking Stem Extension	3/8" to 2"
-56-	Multifill Seats & Graphite Packing	3/8" to 4"
-57-	Oxygen Cleaned	3/8" to 4"
-58-	Chain Lever - Horizontal	1/2" to 2"
-59-	SS External Trim - 3-pc. Valves	3/8" to 4"
-60-	Grounded Ball & Stem	3/8" to 4"

VARIATIONS AVAILABLE:

82-240 Series (316 SS Ball & Stem)

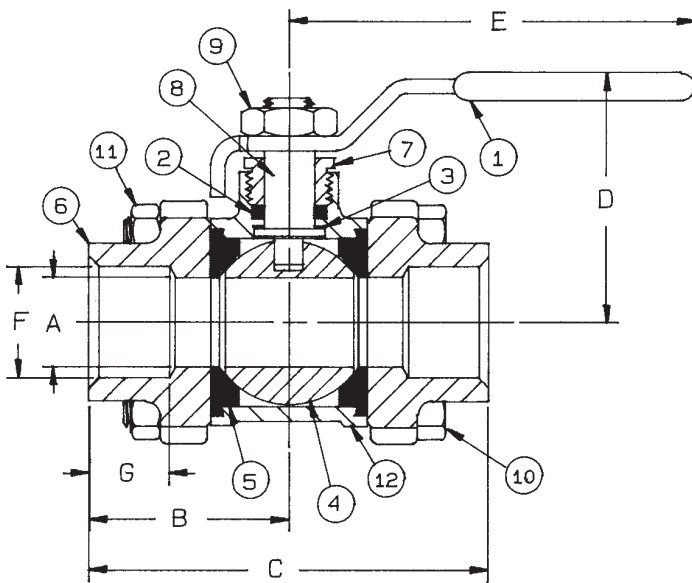

BRONZE 3-PIECE FULL PORT BALL VALVE

NUMBER	SIZE	A	B	C	D	E	F	G	Wt.
82-202-01	3/8"	.50	1.28	2.56	1.81	3.87	.505	.37	.99
82-203-01	1/2"	.62	1.40	2.81	1.93	4.87	.630	.50	1.46
82-204-01	3/4"	.81	1.71	3.43	2.18	4.87	.880	.75	2.07
82-205-01	1"	1.00	1.93	3.87	2.62	5.50	1.130	.90	3.03
82-206-01	1-1/4"	1.25	2.37	4.75	2.87	5.50	1.380	.96	5.02
82-207-01	1-1/2"	1.50	2.60	5.25	3.37	8.00	1.630	1.09	7.91
82-208-01	2"	2.00	3.01	6.03	3.68	8.00	2.130	1.34	13.50
82-209-01	2-1/2"	2.50	3.62	7.25	5.14	9.38	2.630	1.47	26.61
82-240-01	3"	3.00	4.00	8.00	6.77	18.00	3.130	1.66	42.24
82-24A-01	4"	4.00	5.50	11.00	8.26	18.00	4.130	2.16	88.40

**For Pressure/Temperature Ratings,
Refer to Page M-8, Graph No. 4**

Apollo® 83R-100 Series

Carbon Steel 3-Piece Full Port Ball Valve With Actuator Ready ISO Mounting Pad

Full Port Threaded, 1/4" to 1" 1000 psig WOG, 1-1/4" to 3" 800 psig WOG, Cold Non-Shock. 150 psig Saturated Steam. Vacuum Service to 29 inches Hg.

Federal Specification: WW-V-35C, Type: II, Composition: CS, Style: 1.

MSS SP-110; Ball Valve Threaded, Socket-Welding, Solder Joint, Grooved and Flared Ends.

FEATURES

- Multi-piece packing set
- ISO 5211 mounting pad
- Blow-out-proof stem design
- In-line repairable
- Adjustable packing gland
- Investment cast components
- RPTFE seats and seals
- Full port configuration

STANDARD MATERIAL LIST

1. Stem	A108-CS	7. Hex nut (4)	Stl-gr. 8-zinc plt
2. Jam nut	Steel, zinc plate	8. Seat (2)	RPTFE
3. Low profile nut	316 SS	9. Ball	A108-CS chrome plate
4. Gland	A276-316	10. Body bolt (4)	Stl-gr. 8-zinc plt
5. Stem bearing	RPTFE	11. Stem packing	MPTFE
6. End cap (2)	A108-CS (1/4" to 1")	12. Body	ASTM A216-WCB
	A216-WCB (1-1/4" to 3")	13. Lock tab washer	304 SS
		14. Lever and grip	Stl-zinc plt-w/vinyl

VARIATIONS AVAILABLE:

- 83R-140 Series (316 SS Ball & Stem)
- Meets NACE MR-01-75 (1-1/4" to 2")

OPTIONS AVAILABLE:

(SUFFIX)	OPTION	SIZES
-02-	Static Grounded	1/4" to 3"
-03-	1-1/4" Stem Extension	1/4" to 2"
-04-	2-1/4" Stem Extension	1/4" to 2"
-08-	90° Reversed Stem	1/4" to 2"
-10-	SS Lever & Nut	1/4" to 3"
-14-	Vented Ball	1/4" to 3"
-18-	Plain Yellow Grip	1/4" to 3"
-21-	UHMWPE Seats (Non-PTFE)	1/4" to 3"
-24-	Graphite Stem Packing	1/4" to 3"
-27-	Latch Lock Lever	1/2" to 2"
-35-	VTFE Trim	1/4" to 3"
-36-	SS Round Handle	1/4" to 2"
-39-	SS Hi-Rise Locking Wheel Handle, SS Nut	1/4" to 2"
-56-	Multifill Seats & Graphite Packing	1/4" to 3"
-59-	SS External Trim - 3-pc. Valves	1/4" to 3"
-60-	Grounded Ball & Stem	1/4" to 3"
-65-	Multifill Seats & Graphite Packing	1/4" to 3"
-P01-	BSPP (Parallel) Thread Connection	1/4" to 2"
-T01-	BSPT (Tapered) Thread Connection	1/4" to 2"
-AR-	Less Handle & Stop-Add Belleville Washers	1/4" to 3"
-WB-	With Lever & Belleville Washers	1/4" to 3"

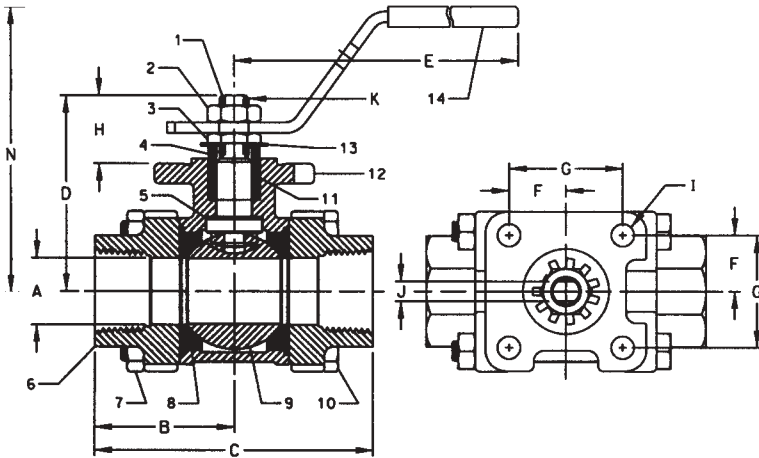

For Pressure/Temperature Ratings, Refer to Page M-10, Graph No. 7

CARBON STEEL 3-PIECE FULL PORT BALL VALVE WITH ISO MOUNTING PAD

NUMBER	SIZE	A	B	C	D	E	F	G	H	I	J (FLATS)	K (THRDS.) UNF	N
83R-101-01	1/4"	.43	1.40	2.81	2.05	4.18	.59	1.17	.61	.28	.247/.249	3/8-24	3.28
83R-102-01	3/8"	.50	1.40	2.81	2.05	4.18	.59	1.17	.61	.28	.247/.249	3/8-24	3.28
83R-103-01	1/2"	.62	1.40	2.81	2.05	4.18	.59	1.17	.61	.28	.247/.249	3/8-24	3.28
83R-104-01	3/4"	.81	1.71	3.42	2.42	4.93	.70	1.39	.84	.28	.247/.249	3/8-24	3.52
83R-105-01	1"	1.00	1.92	3.85	2.54	4.93	.70	1.39	.84	.28	.247/.249	3/8-24	3.64
83R-106-01	1-1/4"	1.25	2.35	4.70	3.16	8.06	.98	1.95	1.16	.34	.370/.372	5/8-18	4.06
83R-107-01	1-1/2"	1.50	2.59	5.18	3.49	8.06	.98	1.95	1.16	.34	.370/.372	5/8-18	4.38
83R-108-01	2"	2.00	3.01	6.03	3.95	8.06	.98	1.95	1.16	.34	.370/.372	5/8-18	4.85
83R-100-01	3"	3.00	4.00	8.00	6.44	19.13	1.42	2.84	1.69	3/8-16	.725	N/A	8.14

Apollo® 83R-200 Series

Carbon Steel 3-Piece Full Port Socket Weld Ball Valve With Actuator Ready ISO Mounting Pad

Socket Weld, 1/2" to 1" 1000 psig WOG, 1-1/4" & 2" 800 psig WOG, Cold Non-Shock. 150 psig Saturated Steam. Vacuum Service to 29 inches Hg.

Federal Specification: WW-V-35C, Type: II, Composition: CS, Style: 1.

MSS SP-110; Ball Valve Threaded, Socket-Welding, Solder Joint, Grooved and Flared Ends.

FEATURES

- Multi-piece packing set
- Adjustable packing gland
- ISO 5211 mounting pad
- Investment cast components
- Blow-out-proof stem design
- RPTFE seats and seals
- In-line repairable
- Full port configuration

STANDARD MATERIAL LIST

1. Stem	A108-CS	7. Hex nut (4)	Stl-gr. 8-zinc plt
2. Jam nut	Steel, zinc plate	8. Seat (2)	RPTFE
3. Low profile nut	316 SS	9. Ball	A108-CS chrome plate
4. Gland	A276-316	10. Body bolt (4)	Stl-gr. 8-zinc plt
5. Stem bearing	RPTFE	11. Stem packing	MPTFE
6. End cap (2)	A108-CS (1/2" to 1")	12. Body	ASTM A216-WCB
	A216-WCB (1-1/4" to 2")	13. Lock tab washer	304 SS
		14. Lever and grip	Stl-zinc plt-w/vinyl

VARIATIONS AVAILABLE:

- 83R-240 Series (316 SS Ball & Stem)
- Meets NACE MR-01-75 (1-1/4" to 2")

OPTIONS AVAILABLE:

(SUFFIX)	OPTION	SIZES
-02-	Static Grounded	1/2" to 3"
-03-	1-1/4" Stem Extension	1/2" to 2"
-04-	2-1/4" Stem Extension	1/2" to 2"
-08-	90° Reversed Stem	1/2" to 2"
-10-	SS Lever & Nut	1/2" to 3"
-14-	Vented Ball	1/2" to 3"
-18-	Plain Yellow Grip	1/2" to 3"
-21-	UHMWPE Seats (Non-PTFE)	1/2" to 3"
-24-	Graphite Stem Packing	1/2" to 3"
-27-	Latch Lock Lever	1/2" to 2"
-35-	VTFE Trim	1/2" to 3"
-36-	SS Round Handle	1/2" to 2"
-39-	SS Hi-Rise Locking Wheel Handle, SS Nut	1/2" to 2"
-59-	SS External Trim - 3-pc. Valves	1/2" to 3"
-60-	Grounded Ball & Stem	1/2" to 3"
-AR-	Less Handle & Stop-Add Belleville Washers	1/2" to 3"
-WB-	With Lever & Belleville Washers	1/2" to 3"

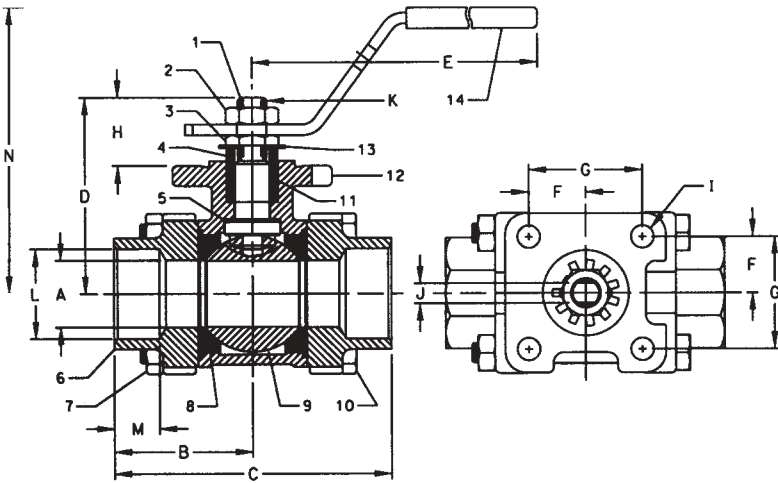

**For Pressure/Temperature Ratings,
Refer to Page M-10, Graph No. 7**

CARBON STEEL 3-PIECE FULL PORT SOCKET WELD BALL VALVE WITH ISO MOUNTING PAD

NUMBER	SIZE	A	B	C	D	E	F	G	H	I	J (FLATS)	K (THRDS.) UNF	L	M	N
83R-203-01	1/2"	.62	1.40	2.81	2.05	4.18	.59	1.17	.61	.28	.247/.249	3/8-24	.855	.43	3.28
83R-204-01	3/4"	.81	1.71	3.42	2.42	4.93	.70	1.39	.84	.28	.247/.249	3/8-24	1.065	.56	3.52
83R-205-01	1"	1.00	1.92	3.85	2.54	4.93	.70	1.39	.84	.28	.247/.249	3/8-24	1.330	.68	3.64
83R-206-01	1-1/4"	1.25	2.35	4.70	3.16	8.06	.98	1.95	1.16	.34	.370/.372	5/8-18	1.675	.81	4.06
83R-207-01	1-1/2"	1.50	2.59	5.18	3.49	8.06	.98	1.95	1.16	.34	.370/.372	5/8-18	1.915	.87	4.38
83R-208-01	2"	2.00	3.01	6.03	3.95	8.06	.98	1.95	1.16	.34	.370/.372	5/8-18	2.405	1.05	4.85
83R-200-01	3"	3.00	4.00	8.00	6.44	19.13	1.42	2.84	1.69	3/8-16	.725	N/A	3.54	1.37	8.14

Apollo® 83R-700 Series

Carbon Steel 3-Piece Full Port Butt-Weld Ball Valve With Actuator Ready ISO Mounting Pad

Schedule 40 Butt-Weld Ends, 1/2" to 1" 1000 psig WOG, 1-1/2" & 2" 800 psig WOG, Cold Non-Shock. 150 psig Saturated Steam.

Vacuum Service to 29 inches Hg.

Federal Specification: WW-V-35C, Type: II, Composition: CS, Style: 1.

MSS SP-72; Ball Valves with Flanged or Butt-Weld Ends for General Service.

FEATURES

- Multi-piece packing set
- ISO 5211 mounting pad
- Blow-out-proof stem design
- In-line repairable
- Adjustable packing gland
- Investment cast components
- RPTFE seats and seals
- Full port configuration

STANDARD MATERIAL LIST

1. Stem	A108-CS	7. Hex nut (4)	Stl-gr. 8-zinc plt
2. Jam nut	Steel, zinc plate	8. Seat (2)	RPTFE
3. Low profile nut	316 SS	9. Ball	A108-CS chrome plate
4. Gland	A276-316	10. Body bolt (4)	Stl-gr. 8-zinc plt
5. Stem bearing	RPTFE	11. Stem packing	MPTFE
6. End cap (2)	A108-CS (1/2" to 1")	12. Body	ASTM A216-WCB
	A216-WCB (1-1/4" to 2")	13. Lock tab washer	304 SS
		14. Lever and grip	Stl-zinc plt-w/vinyl

VARIATIONS AVAILABLE:

- 83R-740 Series (316 SS Ball & Stem)
- Meets NACE MR-01-75 (1-1/4" to 2")

OPTIONS AVAILABLE:

(SUFFIX)	OPTION	SIZES
-02-	Static Grounded	1/2" to 2"
-03-	1-1/4" Stem Extension	1/2" to 2"
-04-	2-1/4" Stem Extension	1/2" to 2"
-08-	90° Reversed Stem	1/2" to 2"
-10-	SS Lever & Nut	1/2" to 2"
-14-	Vented Ball	1/2" to 2"
-18-	Plain Yellow Grip	1/2" to 2"
-21-	UHMWPE Seats (Non-PTFE)	1/2" to 2"
-24-	Graphite Stem Packing	1/2" to 2"
-27-	Latch Lock Lever	1/2" to 2"
-35-	VTFE Trim	1/2" to 2"
-36-	SS Round Handle	1/2" to 2"
-39-	SS Hi-Rise Locking Wheel Handle, SS Nut	1/2" to 2"
-59-	SS External Trim - 3-pc. Valves	1/2" to 2"
-60-	Grounded Ball & Stem	1/2" to 2"
-AR-	Less Handle & Stop-Add Belleville Washers	1/2" to 2"
-WB-	With Lever & Belleville Washers	1/2" to 2"

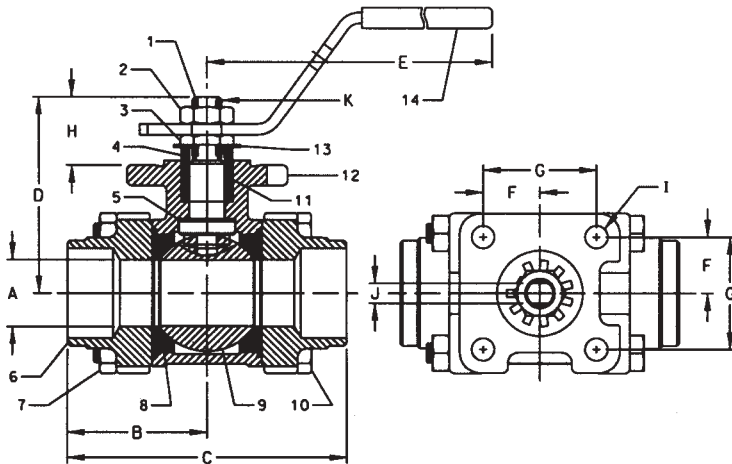

**For Pressure/Temperature Ratings,
Refer to Page M-10, Graph No. 7**

CARBON STEEL 3-PIECE FULL PORT BUTT-WELD BALL VALVE WITH ISO MOUNTING PAD

NUMBER	SIZE	A	B	C	D	E	F	G	H	I	J (FLATS)	K (THRDS.) UNF
83R-703-01	1/2"	.62	1.40	2.81	2.05	4.18	.59	1.17	.61	.28	.247/.249	3/8-24
83R-704-01	3/4"	.81	1.71	3.42	2.42	4.93	.70	1.39	.84	.28	.247/.249	3/8-24
83R-705-01	1"	1.00	1.98	3.97	2.54	4.93	.70	1.39	.84	.28	.247/.249	3/8-24
83R-707-01	1-1/2"	1.50	2.59	5.18	3.49	8.06	.98	1.95	1.16	.34	.370/.372	5/8-18
83R-708-01	2"	2.00	3.01	6.03	3.95	8.06	.98	1.95	1.16	.34	.370/.372	5/8-18

Apollo® 85R-100 Series

Stainless Steel 3-Piece Ball Valve With Actuator Ready ISO Mounting Pad

Std. Port Threaded, 3/4" to 1-1/4" 1000 psig WOG, 1-1/2" & 2" 800 psig WOG, Cold Non-Shock. 150 psig Saturated Steam. Vacuum Service to 29 inches Hg.

Federal Specification: WW-V-35C, Type: II, Composition: SS, Style: 1.

MSS SP-110; Ball Valve Threaded, Socket-Welding, Solder Joint, Grooved and Flared Ends.

FEATURES

- Multi-piece packing set
- ISO 5211 mounting pad
- Blow-out-proof stem design
- In-line repairable
- Adjustable packing gland
- Investment cast components
- RPTFE seats and seals
- Full port configuration
- Meets NACE MR01-75

STANDARD MATERIAL LIST

1. Stem	A276-316	8. Seat (2)	RPTFE
2. Jam nut	SS	9. Ball	316 SS
3. Low profile nut	316 SS	10. Body bolt (4)	18-8 SS
4. Gland	A276-316	11. Stem packing	MPTFE
5. Stem bearing	RPTFE	12. Body	ASTM A351-CF8M
6. End cap (2)	ASTM A351-CF3M	13. Lock tab washer	304 SS
7. Hex nut (4)	18-8 SS	14. Lever and grip	304 SS w/vinyl

OPTIONS AVAILABLE:

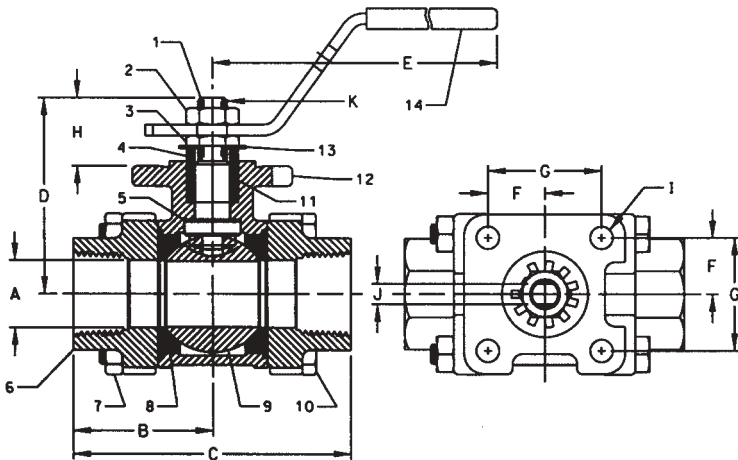

(SUFFIX)	OPTION	SIZES
-02-	Static Grounded	3/4" to 2"
-03-	1-1/4" Stem Extension	3/4" to 2"
-04-	2-1/4" Stem Extension	3/4" to 2"
-08-	90° Reversed Stem	3/4" to 2"
-14-	Vented Ball	3/4" to 2"
-18-	Plain Yellow Grip	3/4" to 2"
-21-	UHMWPE Seats (Non-PTFE)	3/4" to 2"
-24-	Graphite Stem Packing	3/4" to 2"
-27-	Latch Lock Lever	3/4" to 2"
-35-	VTFE Trim	3/4" to 2"
-36-	SS Round Handle	3/4" to 2"
-39-	SS Hi-Rise Locking Wheel Handle, SS Nut	3/4" to 2"
-49-	Assembled Dry	3/4" to 2"
-57-	Oxygen Cleaned	3/4" to 2"
-60-	Grounded Ball & Stem	3/4" to 2"
-63-	Threaded x Socket Weld	3/4" to 2"
-P01-	BSPP (Parallel) Thread Connection	3/4" to 2"
-T01-	BSPT (Tapered) Thread Connection	3/4" to 2"
-AR-	Less Handle & Stop-Add Belleville Washers	3/4" to 2"
-WB-	With Lever & Belleville Washers	3/4" to 2"

**For Pressure/Temperature Ratings,
Refer to Page M-10, Graph No. 8**

STAINLESS STEEL 3-PIECE STANDARD PORT
BALL VALVE WITH ISO MOUNTING PAD

NUMBER	SIZE	A	B	C	D	E	F	G	H	I	J (FLATS)	K (THRDS.) UNF
85R-104-01	3/4"	.62	1.40	2.81	2.05	4.18	.59	1.17	.61	.28	.247/.249	3/8-24
85R-105-01	1"	.81	1.71	3.42	2.42	4.93	.70	1.39	.84	.28	.247/.249	3/8-24
85R-106-01	1-1/4"	1.00	1.92	3.85	2.54	4.93	.70	1.39	.84	.28	.247/.249	3/8-24
85R-107-01	1-1/2"	1.25	2.35	4.70	3.16	8.06	.98	1.95	1.16	.34	.370/.372	5/8-18
85R-108-01	2"	1.50	2.59	5.18	3.49	8.06	.98	1.95	1.16	.34	.370/.372	5/8-18

Apollo® 85R-200 Series

Stainless Steel 3-Piece Standard Port Socket Weld Ball Valve With Actuator Ready ISO Mounting Pad

Socket Weld, 3/4" to 1-1/4" 1000 psig WOG, 1-1/2" & 2" 800 psig WOG, Cold Non-Shock. 150 psig Saturated Steam. Vacuum Service to 29 inches Hg.
 Federal Specification: WW-V-35C, Type: II, Composition: SS, Style: 1.
 MSS SP-110; Ball Valve Threaded, Socket-Welding, Solder Joint, Grooved and Flared Ends.

FEATURES

- Multi-piece packing set
- ISO 5211 mounting pad
- Blow-out-proof stem design
- In-line repairable
- Adjustable packing gland
- Investment cast components
- RPTFE seats and seals
- Standard port configuration
- Meets NACE MR01-75

STANDARD MATERIAL LIST

1. Stem	A276-316	8. Seat (2)	RPTFE
2. Jam nut	SS	9. Ball	316 SS
3. Low profile nut	316 SS	10. Body bolt (4)	18-8 SS
4. Gland	A276-316	11. Stem packing	MPTFE
5. Stem bearing	RPTFE	12. Body	ASTM A351-CF8M
6. End cap (2)	ASTM A351-CF3M	13. Lock tab washer	304 SS
7. Hex nut (4)	18-8 SS	14. Lever and grip	304 SS w/vinyl

OPTIONS AVAILABLE:

(SUFFIX)	OPTION	SIZES
-02-	Static Grounded	3/4" to 2"
-03-	1-1/4" Stem Extension	3/4" to 2"
-04-	2-1/4" Stem Extension	3/4" to 2"
-08-	90° Reversed Stem	3/4" to 2"
-14-	Vented Ball	3/4" to 2"
-18-	Plain Yellow Grip	3/4" to 2"
-21-	UHMWPE Seats (Non-PTFE)	3/4" to 2"
-24-	Graphite Stem Packing	3/4" to 2"
-27-	Latch Lock Lever	3/4" to 2"
-35-	VTFE Trim	3/4" to 2"
-36-	SS Round Handle	3/4" to 2"
-39-	SS Hi-Rise Locking Wheel Handle, SS Nut	3/4" to 2"
-49-	Assembled Dry	3/4" to 2"
-57-	Oxygen Cleaned	3/4" to 2"
-60-	Grounded Ball & Stem	3/4" to 2"
-AR-	Less Handle & Stop-Add Belleville Washers	3/4" to 2"
-WB-	With Lever & Belleville Washers	3/4" to 2"

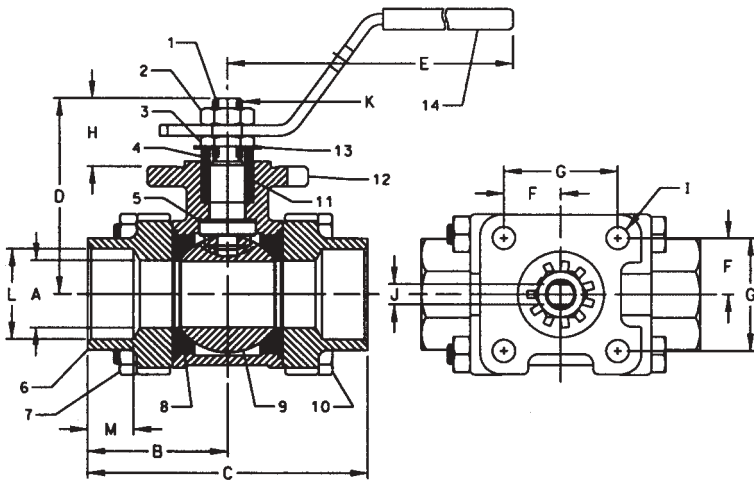

**For Pressure/Temperature Ratings,
 Refer to Page M-10, Graph No. 8**

STAINLESS STEEL 3-PIECE STANDARD PORT SOCKET WELD BALL VALVE WITH ISO MOUNTING PAD

NUMBER	SIZE	A	B	C	D	E	F	G	H	I	J (FLATS)	K (THRDS.) UNF	L	M
85R-204-01	3/4"	.62	1.40	2.81	2.05	4.18	.59	1.17	.61	.28	.247/.249	3/8-24	1.065	.56
85R-205-01	1"	.81	1.71	3.42	2.42	4.93	.70	1.39	.84	.28	.247/.249	3/8-24	1.330	.68
85R-206-01	1-1/4"	1.00	1.92	3.85	2.54	4.93	.70	1.39	.84	.28	.247/.249	3/8-24	1.675	.81
85R-207-01	1-1/2"	1.25	2.35	4.70	3.16	8.06	.98	1.95	1.16	.34	.370/.372	5/8-18	1.915	.87
85R-208-01	2"	1.50	2.59	5.18	3.49	8.06	.98	1.95	1.16	.34	.370/.372	5/8-18	2.406	1.06

Apollo® 86R-100 Series

Stainless Steel 3-Piece Full Port Ball Valve With Actuator Ready ISO Mounting Pad

Full Port Threaded, 1/4" to 1" 1000 psig WOG, 1-1/4" to 3" 800 psig WOG, Cold Non-Shock. 150 psig Saturated Steam. Vacuum Service to 29 inches Hg.

Federal Specification: WW-V-35C, Type: II, Composition: SS, Style: 1.

MSS SP-110; Ball Valve Threaded, Socket-Welding, Solder Joint, Grooved and Flared Ends.

FEATURES

- Multi-piece packing set
- Adjustable packing gland
- ISO 5211 mounting pad
- Investment cast components
- Blow-out-proof stem design
- RPTFE seats and seals
- In-line repairable
- Full port configuration
- Meets NACE MR01-75

STANDARD MATERIAL LIST

1. Stem	A276-316	8. Seat (2)	RPTFE
2. Jam nut	SS	9. Ball	316 SS
3. Low profile nut	316 SS	10. Body bolt (4)	18-8 SS
4. Gland	A276-316	11. Stem packing	MPTFE
5. Stem bearing	RPTFE	12. Body	ASTM A351-CF8M
6. End cap (2)	ASTM A351-CF3M	13. Lock tab washer	304 SS
7. Hex nut (4)	18-8 SS	14. Lever and grip	304 SS w/vinyl

OPTIONS AVAILABLE:

(SUFFIX)	OPTION	SIZES
-02-	Static Grounded	1/4" to 3"
-03-	1-1/4" Stem Extension	1/4" to 2"
-04-	2-1/4" Stem Extension	1/4" to 2"
-08-	90° Reversed Stem	1/4" to 2"
-14-	Vented Ball	1/4" to 3"
-18-	Plain Yellow Grip	1/4" to 3"
-21-	UHMWPE Seats (Non-PTFE)	1/4" to 2"
-24-	Graphite Stem Packing	1/4" to 3"
-27-	Latch Lock Lever	1/4" to 2"
-35-	VTFE Trim	1/4" to 3"
-36-	SS Round Handle	1/4" to 2"
-39-	SS Hi-Rise Locking Wheel Handle, SS Nut	1/4" to 2"
-49-	Assembled Dry	1/4" to 3"
-57-	Oxygen Cleaned	1/4" to 3"
-60-	Grounded Ball & Stem	1/4" to 3"
-63-	Threaded x Socket Weld	1/4" to 2"
-P01-	BSPP (Parallel) Thread Connection	1/4" to 2"
-T01-	BSPT (Tapered) Thread Connection	1/4" to 2"
-AR-	Less Handle & Stop-Add Belleville Washers	1/4" to 3"
-WB-	With Lever & Belleville Washers	1/4" to 3"

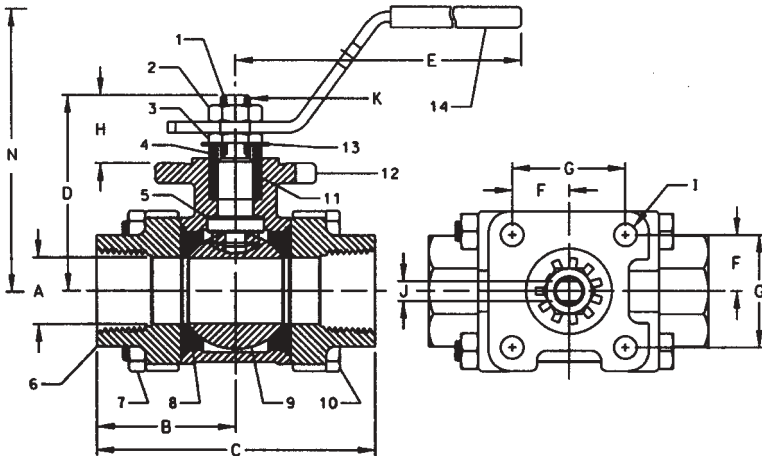

**For Pressure/Temperature Ratings,
Refer to Page M-10, Graph No. 8**

STAINLESS STEEL 3-PIECE FULL PORT BALL VALVE WITH ISO MOUNTING PAD

NUMBER	SIZE	A	B	C	D	E	F	G	H	I	J (FLATS)	K (THRDS.) UNF	N
86R-101-01	1/4"	.43	1.40	2.81	2.05	4.18	.59	1.17	.61	.28	.247/.249	3/8-24	3.28
86R-102-01	3/8"	.50	1.40	2.81	2.05	4.18	.59	1.17	.61	.28	.247/.249	3/8-24	3.28
86R-103-01	1/2"	.62	1.40	2.81	2.05	4.18	.59	1.17	.61	.28	.247/.249	3/8-24	3.28
86R-104-01	3/4"	.81	1.71	3.42	2.42	4.93	.70	1.39	.84	.28	.247/.249	3/8-24	3.52
86R-105-01	1"	1.00	1.92	3.85	2.54	4.93	.70	1.39	.84	.28	.247/.249	3/8-24	3.64
86R-106-01	1-1/4"	1.25	2.35	4.70	3.16	8.06	.98	1.95	1.16	.34	.370/.372	5/8-18	4.06
86R-107-01	1-1/2"	1.50	2.59	5.18	3.49	8.06	.98	1.95	1.16	.34	.370/.372	5/8-18	4.38
86R-108-01	2"	2.00	3.01	6.03	3.95	8.06	.98	1.95	1.16	.34	.370/.372	5/8-18	4.85
86R-100-01	3"	3.00	4.00	8.00	6.44	19.13	1.42	2.84	1.69	3/8-16	.725	NA	8.14

Apollo® 86R-200 Series

Stainless Steel 3-Piece Full Port Socket Weld Valve Ball Valve With Actuator Ready ISO Mounting Pad

Socket Weld, 1/4" to 1" 1000 psig WOG, 1-1/4" to 3" 800 psig WOG, Cold Non-Shock. 150 psig Saturated Steam. Vacuum Service to 29 inches Hg.

Federal Specification: WW-V-35C, Type: II, Composition: SS, Style: 1.

MSS SP-110; Ball Valve Threaded, Socket-Welding, Solder Joint, Grooved and Flared Ends.

FEATURES

- Multi-piece packing set
- ISO 5211 mounting pad
- Blow-out-proof stem design
- In-line repairable
- Adjustable packing gland
- Investment cast components
- RPTFE seats and seals
- Full port configuration
- Meets NACE MR01-75

STANDARD MATERIAL LIST

1. Stem	A276-316	8. Seat (2)	RPTFE
2. Jam nut	SS	9. Ball	316 SS
3. Low profile nut	316 SS	10. Body bolt (4)	18-8 SS
4. Gland	A276-316	11. Stem packing	MPTFE
5. Stem bearing	RPTFE	12. Body	ASTM A351-CF8M
6. End cap (2)	ASTM A351-CF3M	13. Lock tab washer	304 SS
7. Hex nut (4)	18-8 SS	14. Lever and grip	304 SS w/vinyl

OPTIONS AVAILABLE:

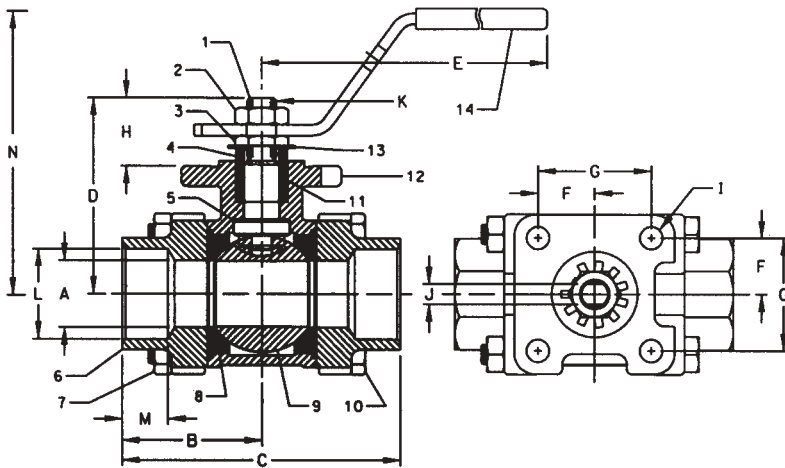

(SUFFIX)	OPTION	SIZES
-02-	Static Grounded	1/4" to 3"
-03-	1-1/4" Stem Extension	1/4" to 2"
-04-	2-1/4" Stem Extension	1/4" to 2"
-08-	90° Reversed Stem	1/4" to 2"
-14-	Vented Ball	1/4" to 3"
-18-	Plain Yellow Grip	1/4" to 3"
-21-	UHMWPE Seats (Non-PTFE)	1/4" to 2"
-24-	Graphite Stem Packing	1/4" to 3"
-27-	Latch Lock Lever	1/4" to 2"
-35-	VTFE Trim	1/4" to 3"
-36-	SS Round Handle	3/4" to 2"
-39-	SS Hi-Rise Locking Wheel Handle, SS Nut	1/4" to 2"
-49-	Assembled Dry	1/4" to 3"
-56-	Multi-fill Seats	1/4" to 3"
-57-	Oxygen Cleaned	1/4" to 3"
-60-	Grounded Ball & Stem	1/4" to 3"
-AR-	Less Handle & Stop-Add Belleville Washers	1/4" to 3"
-WB-	With Lever & Belleville Washers	1/4" to 3"

**For Pressure/Temperature Ratings,
Refer to Page M-10, Graph No. 8**

STAINLESS STEEL 3-PIECE FULL PORT SOCKET WELD BALL VALVE WITH ISO MOUNTING PAD

NUMBER	SIZE	A	B	C	D	E	F	G	H	I	J (FLATS)	K (THRDS.) UNF	L	M	N
86R-201-01	1/4"	.43	1.40	2.81	2.05	4.18	.59	1.17	.61	.28	.247/.249	3/8-24	.565	.50	3.28
86R-202-01	3/8"	.50	1.40	2.81	2.05	4.18	.59	1.17	.61	.28	.247/.249	3/8-24	.700	.56	3.28
86R-203-01	1/2"	.62	1.40	2.81	2.05	4.18	.59	1.17	.61	.28	.247/.249	3/8-24	.855	.43	3.28
86R-204-01	3/4"	.81	1.71	3.42	2.42	4.93	.70	1.39	.84	.28	.247/.249	3/8-24	1.065	.56	3.52
86R-205-01	1"	1.00	1.92	3.85	2.54	4.93	.70	1.39	.84	.28	.247/.249	3/8-24	1.330	.68	3.64
86R-206-01	1-1/4"	1.25	2.35	4.70	3.16	8.06	.98	1.95	1.16	.34	.370/.372	5/8-18	1.675	.81	4.06
86R-207-01	1-1/2"	1.50	2.59	5.18	3.49	8.06	.98	1.95	1.16	.34	.370/.372	5/8-18	1.915	.87	4.38
86R-208-01	2"	2.00	3.01	6.03	3.95	8.06	.98	1.95	1.16	.34	.370/.372	5/8-18	2.405	1.05	4.85
86R-200-01	3"	3.00	4.00	8.00	6.44	19.13	1.42	2.84	1.69	3/8-16	.725	N/A	3.54	1.37	8.14

Apollo® 86R-700 Series

Stainless Steel 3-Piece Full Port Butt-Weld Ball Valve With Actuator Ready ISO Mounting Pad

Schedule 10 Butt-Weld Ends, 1/2" to 1" 1000 psig WOG, 1-1/2" & 2" 800 psig WOG, Cold Non-Shock. 150 psig Saturated Steam.

Vacuum Service to 29 inches Hg.

Federal Specification: WW-V-35C, Type: II, Composition: SS, Style: 1.

MSS SP-72; Ball Valves with Flanged or Butt-Weld Ends for General Service.

FEATURES

- Multi-piece packing set
- ISO 5211 mounting pad
- Blow-out-proof stem design
- In-line repairable
- Adjustable packing gland
- Investment cast components
- RPTFE seats and seals
- Full port configuration
- Meets NACE MR01-75

STANDARD MATERIAL LIST

1. Stem	A276-316	8. Seat (2)	RPTFE
2. Jam nut	SS	9. Ball	316 SS
3. Low profile nut	316 SS	10. Body bolt (4)	18-8 SS
4. Gland	A276-316	11. Stem packing	MPTFE
5. Stem bearing	RPTFE	12. Body	ASTM A351-CF8M
6. End cap (2)	ASTM A351-CF3M	13. Lock tab washer	304 SS
7. Hex nut (4)	18-8 SS	14. Lever and grip	304 SS w/vinyl

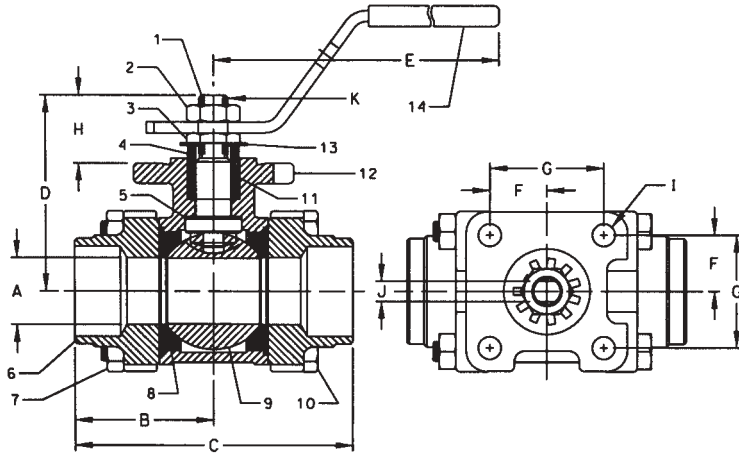

OPTIONS AVAILABLE:

(SUFFIX)	OPTION	SIZES
-02-	Static Grounded	1/2" to 2"
-03-	1-1/4" Stem Extension	1/2" to 2"
-04-	2-1/4" Stem Extension	1/2" to 2"
-08-	90° Reversed Stem	1/2" to 2"
-14-	Vented Ball	1/2" to 2"
-18-	Plain Yellow Grip	1/2" to 2"
-21-	UHMWPE Seats (Non-PTFE)	1/2" to 2"
-24-	Graphite Stem Packing	1/2" to 2"
-27-	Latch Lock Lever	1/2" to 2"
-35-	VTFE Trim	1/2" to 2"
-36-	SS Round Handle	1/4" to 2"
-39-	SS Hi-Rise Locking Wheel Handle, SS Nut	1/2" to 2"
-49-	Assembled Dry	1/2" to 2"
-57-	Oxygen Cleaned	1/2" to 2"
-60-	Grounded Ball & Stem	1/2" to 2"
-AR-	Less Handle & Stop-Add Belleville Washers	1/2" to 2"
-WB-	With Lever & Belleville Washers	1/2" to 2"

**For Pressure/Temperature Ratings,
Refer to Page M-10, Graph No. 8**

STAINLESS STEEL 3-PIECE FULL PORT BUTT WELD BALL VALVE WITH ISO MOUNTING PAD

NUMBER	SIZE	A	B	C	D	E	F	G	H	I	J (FLATS)	K (THRDS.) UNF
86R-703-01	1/2"	.62	1.40	2.81	2.05	4.18	.59	1.17	.61	.28	.247/.249	3/8-24
86R-704-01	3/4"	.81	1.71	3.42	2.42	4.93	.70	1.39	.84	.28	.247/.249	3/8-24
86R-705-01	1"	1.00	1.98	3.97	2.54	4.93	.70	1.39	.84	.28	.247/.249	3/8-24
86R-707-01	1-1/2"	1.50	2.59	5.18	3.49	8.06	.98	1.95	1.16	.34	.370/.372	5/8-18
86R-708-01	2"	2.00	3.01	6.03	3.95	8.06	.98	1.95	1.16	.34	.370/.372	5/8-18

Apollo® 401R-100 Series

Alloy 20 3-Piece Full Port Ball Valve With Actuator Ready ISO Mounting Pad

Full Port Threaded, 1/2" to 1" 1000 psig WOG, 1-1/2" to 3" 800 psig WOG, Cold Non-Shock. 150 psig Saturated Steam.

Vacuum Service to 29 inches Hg.

Federal Specification: WW-V-35C, Type: II, Composition: SS, Style: 1.

MSS SP-110; Ball Valves, Threaded, Socket-Welding, Solder Joint, Grooved and Flared Ends.

FEATURES

- Multi-piece packing set
- Adjustable packing gland
- ISO 5211 mounting pad
- Investment cast components
- Blow-out-proof stem design
- RPTFE seats and seals
- In-line repairable
- Full port configuration
- Meets NACE MR01-75

STANDARD MATERIAL LIST

1. Stem	B473-N08020	8. Seat (2)	RPTFE
2. Jam nut	SS	9. Ball	B473-N08020
3. Low profile nut	316 SS	10. Body bolt (4)	18-8 SS
4. Gland	A276-316	11. Stem packing	MPTFE
5. Stem bearing	RPTFE	12. Body	ASTM A351-CN7M
6. End cap (2)	ASTM A351-CN7M	13. Lock tab washer	304 SS
7. Hex nut (4)	18-8 SS	14. Lever and grip	304 SS w/vinyl

OPTIONS AVAILABLE:

(SUFFIX)	OPTION	SIZES
-02-	Static Grounded	1/2" to 3"
-03-	1-1/4" Stem Extension	1/2" to 2"
-04-	2-1/4" Stem Extension	1/2" to 2"
-08-	90° Reversed Stem	1/2" to 2"
-18-	Plain Yellow Grip	1/2" to 3"
-21-	UHMWPE Seats (Non-PTFE)	1/2" to 2"
-24-	Graphite Stem Packing	1/2" to 3"
-27-	Latch Lock Lever	1/2" to 2"
-35-	VTFE Trim	1/2" to 3"
-36-	SS Hi-Rise Round Handle & Nut	1/2" to 2"
-39-	SS Hi-Rise Locking Wheel Handle, SS Nut	1/2" to 2"
-49-	Assembled Dry	1/2" to 3"
-57-	Oxygen Cleaned	1/2" to 3"
-60-	Grounded Ball & Stem	1/2" to 3"
-P01-	BSPP (Parallel) Thread Connection	1/2" to 2"
-T01-	BSPT (Tapered) Thread Connection	1/2" to 2"
-AR-	Less Handle & Stop-Add Belleville Washers	1/2" to 3"
-WB-	With Lever & Belleville Washers	1/2" to 3"

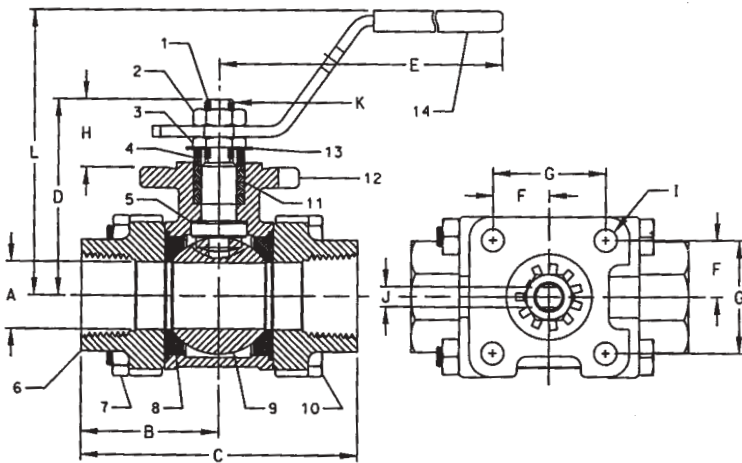

**For Pressure/Temperature Ratings,
Refer to Page M-10, Graph No. 8**

ALLOY 20 3-PC. FULL PORT BV WITH ISO MOUNTING PAD

PART #	SIZE	A	B	C	D	E	F	G	H	I	J (Flats)	K (Thrds.) UNF	L
401R10301	1/2"	.62	1.40	2.81	2.05	4.18	.59	1.17	.61	.28	.247/.249	3/8-24	3.28
401R10401	3/4"	.81	1.71	3.42	2.42	4.93	.70	1.39	.84	.28	.247/.249	3/8-24	3.52
401R10501	1"	1.00	1.92	3.85	2.54	4.93	.70	1.39	.84	.28	.247/.249	3/8-24	3.64
401R10701	1-1/2"	1.50	2.59	5.18	3.49	8.06	.98	1.95	1.16	.34	.370/.372	5/8-18	4.38
401R10801	2"	2.00	3.01	6.03	3.95	8.06	.98	1.95	1.16	.34	.370/.372	5/8-18	4.85
401R10001	3"	3.00	8.00	8.00	6.44	19.13	1.42	2.84	1.67	3/8-16	.725	N/A	8.14

Apollo® 401R-200 Series

Alloy 20 3-Piece Full Port Socket Weld Ball Valve With Actuator Ready ISO Mounting Pad

Socket Weld, 1/2" to 1" 1000 psig WOG, 1-1/2" & 2" 800 psig WOG, Cold Non-Shock. 150 psig Saturated Steam. Vacuum Service to 29 inches Hg.

Federal Specification: WW-V-35C, Type: II, Composition: SS, Style: 1.

MSS SP-110; Ball Valves, Threaded, Socket-Welding, Solder Joint, Grooved and Flared Ends.

FEATURES

- Multi-piece packing set
- ISO 5211 mounting pad
- Blow-out-proof stem design
- In-line repairable
- Meets NACE MR01-75
- Adjustable packing gland
- Investment cast components
- RPTFE seats and seals
- Full port configuration

STANDARD MATERIAL LIST

1. Stem	B473-N08020	8. Seat (2)	RPTFE
2. Jam nut	SS	9. Ball	B473-N08020
3. Low profile nut	316 SS	10. Body bolt (4)	18-8 SS
4. Gland	A276-316	11. Stem packing	MPTFE
5. Stem bearing	RPTFE	12. Body	ASTM A351-CN7M
6. End cap (2)	ASTM A351-CN7M	13. Lock tab washer	304 SS
7. Hex nut (4)	18-8 SS	14. Lever and grip	304 SS w/vinyl

OPTIONS AVAILABLE:

(SUFFIX)	OPTION	SIZES
-02-	Static Grounded	1/2" to 2"
-03-	1-1/4" Stem Extension	1/2" to 2"
-04-	2-1/4" Stem Extension	1/2" to 2"
-08-	90° Reversed Stem	1/2" to 2"
-14-	Vented Ball	1/2" to 2"
-18-	Plain Yellow Grip	1/2" to 2"
-21-	UHMWPE Seats (Non-PTFE)	1/2" to 2"
-24-	Graphite Stem Packing	1/2" to 2"
-27-	Latch Lock Lever	1/2" to 2"
-35-	VTFE Trim	1/2" to 2"
-36-	SS Hi-Rise Round Handle & Nut	1/2" to 2"
-39-	SS Hi-Rise Locking Wheel Handle, SS Nut	1/2" to 2"
-49-	Assembled Dry	1/2" to 2"
-57-	Oxygen Cleaned	1/2" to 2"
-60-	Grounded Ball & Stem	1/2" to 2"
-AR-	Less Handle & Stop-Add Belleville Washers	1/2" to 2"
-WB-	With Lever & Belleville Washers	1/2" to 2"

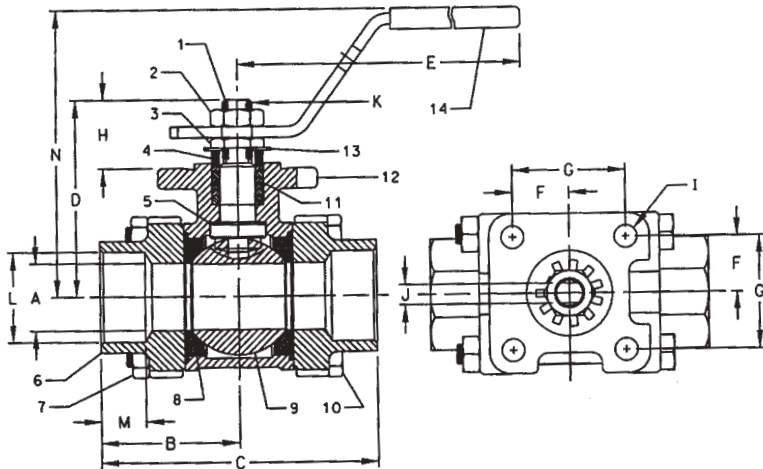

For Pressure/Temperature Ratings, Refer to Page M-10, Graph No. 8

ALLOY 20 3-PC. FULL PORT BV WITH ISO MOUNTING PAD

PART #	SIZE	A	B	C	D	E	F	G	H	I	J (Flats)	K (Thrds.) UNF	L	M	N
401R20301	1/2"	.62	1.40	2.81	2.05	4.18	.59	1.17	.61	.28	.247/.249	3/8-24	.855	.43	3.28
401R20401	3/4"	.81	1.71	3.42	2.42	4.93	.70	1.39	.84	.28	.247/.249	3/8-24	1.065	.56	3.52
401R20501	1"	1.00	1.92	3.85	2.54	4.93	.70	1.39	.84	.28	.247/.249	3/8-24	1.330	.68	3.64
401R20701	1-1/2"	1.50	2.59	5.18	3.49	8.06	.98	1.95	1.16	.34	.370/.372	5/8-18	1.915	.87	4.38
401R20801	2"	2.00	3.01	6.03	3.95	8.06	.98	1.95	1.16	.34	.370/.372	5/8-18	2.405	1.05	4.85

Carbon Steel 3-Piece High Pressure Ball Valve

Standard Port, Threaded, 1/2" to 1-1/4" 1500 psig WOG, 1-1/2" & 2" 1250 psig WOG, Cold Non-Shock. 150 psig Saturated Steam. Vacuum Service to 29 inches Hg.

Federal Specification: WW-V-35C, Type: II, Composition: CS, Style: 1.

MSS SP-110; Ball Valves Threaded, Socket-Welding, Solder Joint, Grooved and Flared Ends.

FEATURES

- Nitride corrosion protection
- Adjustable packing gland
- In-line repairable
- Blow-out-proof stem design
- (-29) certified to API 607 4TH ed. Class 600 burn
- Meets NACE MR-01-75 with SS trim
- Investment Cast Components
- Actuator mounting pad (1" to 2")
- RPTFE seats and seals

STANDARD MATERIAL LIST

1. Lever and grip	CS, zinc plated w/vinyl	8. Gland nut	A108-CS
2. Body bolt (4)	Steel, SAE grade 8 zinc plated	9. Stem	A108-CS
3. Hex nut (4)	Steel, SAE grade 8 zinc plated	10. Lever nut	Steel, zinc plated
4. Ball	A108-CS chrome plated	11. Stem packing	RPTFE
5. Seat (2)	RPTFE	12. Stem bearing	RPTFE
6. End cap (2)	A216-WCB	13. Body	A216-WCB
7. Seat holder (2)	A108-CS	14. Body seal (2)	RPTFE

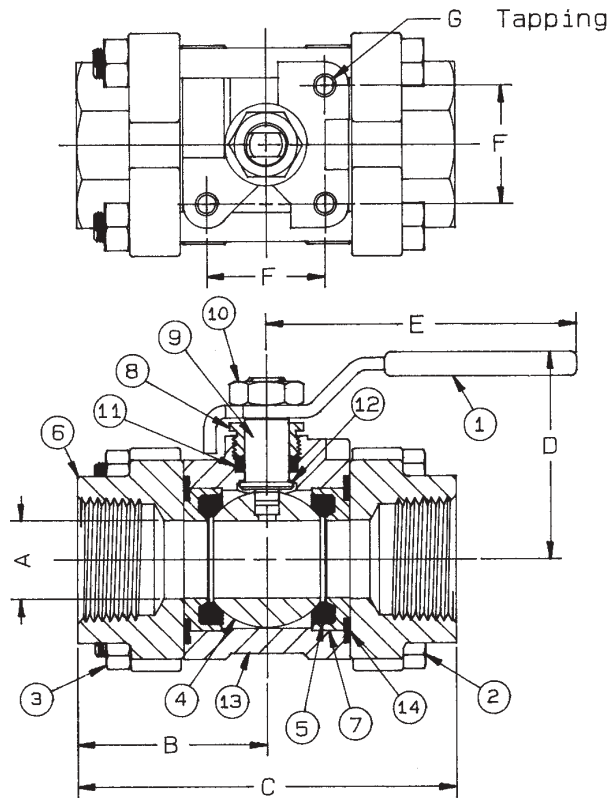

VARIATIONS AVAILABLE:

83-340 Series (316 SS Ball & Stem)

OPTIONS AVAILABLE:

(SUFFIX)	OPTION	SIZES
-02-	Static Grounded	1/2" to 2"
-03-	1-1/4" Stem Extension	1/2" to 2"
-04-	2-1/4" Stem Extension	1/2" to 2"
-07-	Tee Handle	1/2" to 2"
-08-	90° Reversed Stem	1/2" to 2"
-10-	SS Lever & Nut	1/2" to 2"
-14-	Vented Ball (see page J-2)	1/2" to 2"
-15-	Round Handle	1/2" to 2"
-16-	Vertical Chain Lever	3/4" to 2"
-18-	Plain Yellow Grip	1/2" to 2"
-27-	Latch Lock Lever	3/4" to 2"
-29-	Firesafe	1/2" to 2"
-32-	SS Tee Handle & Nut	1/2" to 2"
-45-	Less Lever & Nut	1/2" to 2"
-48-	SS Oval Handle (No Latch) & Nut	1/2" to 2"
-56-	Multifill Seats	1/2" to 2"
-58-	Chain Lever - Horizontal	3/4" to 2"
-59-	SS External Trim - 3-pc. Valves	1/2" to 2"
-60-	Grounded Ball & Stem	1/2" to 2"
-63-	NPT x Socket Weld	1/2" to 2"
-64-	250# Steam Trim	1/2" to 2"
-P01-	BSPP (Parallel) Thread Connection	1/2" to 2"
-T01-	BSPT (Tapered) Thread Connection	1/2" to 2"

CARBON STEEL 3-PIECE
HIGH PRESSURE BALL VALVE

NUMBER	SIZE	A	B	C	D	E	F	G	Wt.
83-303-01	1/2"	.50	1.50	3.00	1.84	3.87	N/A	N/A	1.28
83-304-01	3/4"	.62	1.87	3.74	2.00	4.87	N/A	N/A	2.00
83-305-01A	1"	.81	1.99	3.99	2.18	4.87	1.25	1/4-20	2.69
83-306-01A	1-1/4"	1.00	2.31	4.62	2.60	5.50	1.62	5/16-18	3.97
83-307-01A	1-1/2"	1.25	2.62	5.25	2.82	5.50	1.62	5/16-18	5.50
83-308-01A	2"	1.50	2.74	5.48	3.37	8.00	1.62	5/16-18	8.05

**For Pressure/Temperature Ratings,
Refer to Page M-12, Graph No. 11**

Apollo® 83-400 Series

Carbon Steel 3-Piece High Pressure Socket Weld Ball Valve

Standard Port, Socket Weld, 1/2" to 1-1/4" 1500 psig WOG, 1-1/2" & 2" 1250 psig WOG, Cold Non-Shock. 150 psig Saturated Steam. Vacuum Service to 29 inches Hg.
Federal Specification: WW-V-35C, Type: II, Composition: CS, Style: 1.
MSS SP-110; Ball Valves Threaded, Socket-Welding, Solder Joint, Grooved and Flared Ends.

FEATURES

- Nitride corrosion protection
- Meets NACE MR-01-75 with SS trim
- Adjustable packing gland
- Investment Cast Components
- In-line repairable
- Actuator mounting pad (1" to 2")
- Blow-out-proof stem design
- RPTFE seats and seals
- (-29) certified to API 607 4TH ed. Class 600 burn

STANDARD MATERIAL LIST

1. Lever and grip	CS, zinc plated w/vinyl	8. Gland nut	A108-CS
2. Body bolt (4)	Steel, SAE grade 8 zinc plated	9. Stem	A108-CS
3. Hex nut (4)	Steel, SAE grade 8 zinc plated	10. Lever nut	Steel, zinc plated
4. Ball	A108-CS chrome plated	11. Stem packing	RPTFE
5. Seat (2)	RPTFE	12. Stem bearing	RPTFE
6. End cap (2)	A216-WCB	13. Body	A216-WCB
7. Seat holder (2)	A108-CS	14. Body seal (2)	RPTFE

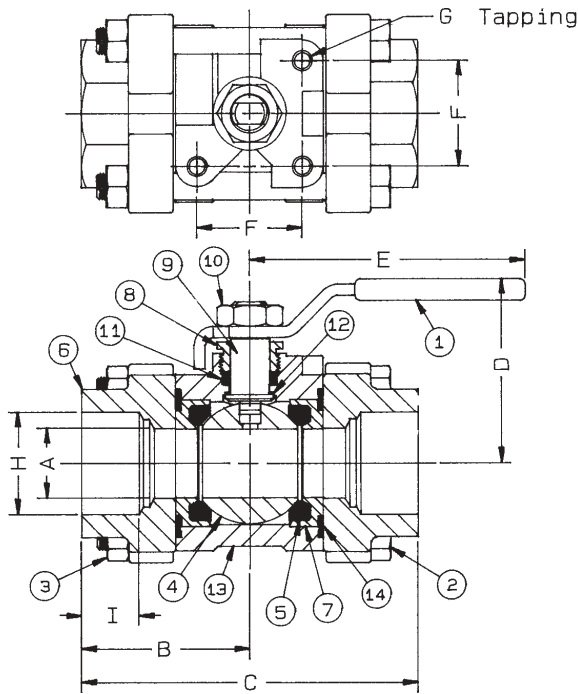

CARBON STEEL 3-PIECE HIGH PRESSURE
SOCKET WELD BALL VALVE

VARIATIONS AVAILABLE:

83-440 Series (316 SS Ball & Stem)

OPTIONS AVAILABLE:

(SUFFIX)	OPTION	SIZES
-02-	Static Grounded	1/2" to 2"
-03-	1-1/4" Stem Extension	1/2" to 2"
-04-	2-1/4" Stem Extension	1/2" to 2"
-07-	Tee Handle	1/2" to 2"
-08-	90° Reversed Stem	1/2" to 2"
-10-	SS Lever & Nut	1/2" to 2"
-14-	Vented Ball (see page J-2)	1/2" to 2"
-15-	Round Handle	1/2" to 2"
-16-	Vertical Chain Lever	3/4" to 2"
-18-	Plain Yellow Grip	1/2" to 2"
-27-	Latch Lock Lever	3/4" to 2"
-29-	Firesafe	1/2" to 2"
-32-	SS Tee Handle & Nut	1/2" to 2"
-45-	Less Lever & Nut	1/2" to 2"
-48-	SS Oval Handle (No Latch) & Nut	1/2" to 2"
-56-	Multifill Seats	1/2" to 2"
-58-	Chain Lever - Horizontal	3/4" to 2"
-59-	SS External Trim - 3-pc. Valves	1/2" to 2"
-60-	Grounded Ball & Stem	1/2" to 2"
-64-	250# Steam Trim	1/2" to 2"

**For Pressure/Temperature Ratings,
Refer to Page M-12, Graph No. 11**

NUMBER	SIZE	A	B	C	D	E	F	G	H	I	Wt.
83-403-01	1/2"	.50	1.50	3.00	1.84	3.87	N/A	N/A	.855	.43	1.28
83-404-01	3/4"	.62	1.87	3.74	2.00	4.87	N/A	N/A	1.065	.56	2.00
83-405-01A	1"	.81	1.99	3.99	2.18	4.87	1.25	1/4-20	1.330	.68	2.69
83-406-01A	1-1/4"	1.00	2.31	4.62	2.60	5.50	1.62	5/16-18	1.675	.81	3.97
83-407-01A	1-1/2"	1.25	2.62	5.25	2.82	5.50	1.62	5/16-18	1.915	.87	5.50
83-408-01A	2"	1.50	2.74	5.48	3.37	8.00	1.62	5/16-18	2.406	1.06	8.05

Carbon Steel 3-Piece High Pressure Full Port Ball Valve

Threaded, 1/4" to 1" 1500 psig WOG, 1-1/4" & 2" 1250 psig WOG, Cold Non-Shock. 150 psig Saturated Steam. Vacuum Service to 29 inches Hg.

Federal Specification: WW-V-35C, Type: II, Composition: CS, Style: 1.

MSS SP-110; Ball Valves Threaded, Socket-Welding, Solder Joint, Grooved and Flared Ends.

FEATURES

- Nitride corrosion protection
- Adjustable packing gland
- In-line repairable
- Blow-out-proof stem design
- (-29) Certified to API standard 607, 4th Edition, Class 600 burn
- Meets NACE MR-01-75 with SS trim
- Investment Cast Components
- Actuator mounting pad (3/4" to 2")
- RPTFE seats and seals

STANDARD MATERIAL LIST

1. Lever and grip	CS, zinc plated w/vinyl	8. Gland nut	A108-CS
2. Body bolt (4)	Steel, SAE grade 8 zinc plated	9. Stem	A108-CS
3. Hex nut (4)	Steel, SAE grade 8 zinc plated	10. Lever nut	Steel, zinc plated
4. Ball	A108-CS chrome plated	11. Stem packing	RPTFE
5. Seat (2)	RPTFE	12. Stem bearing	RPTFE
6. End cap (2)	A216-WCB	13. Body	A216-WCB
7. Seat holder (2)	A108-CS	14. Body seal (2)	RPTFE

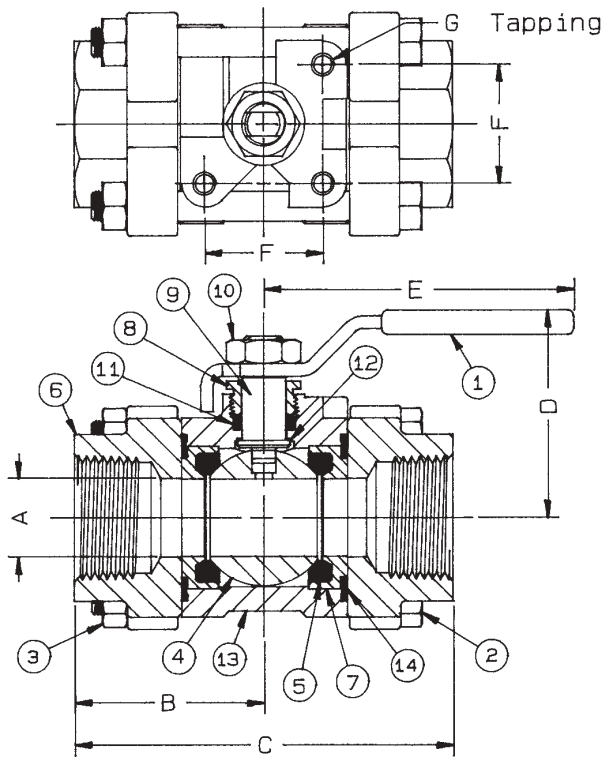

CARBON STEEL 3-PIECE HIGH PRESSURE FULL PORT BALL VALVE

NUMBER	SIZE	A	B	C	D	E	F	G	Wt.
83-501-01	1/4"	.43	1.50	3.00	1.93	3.87	N/A	N/A	1.21
83-502-01	3/8"	.50	1.50	3.00	1.93	3.87	N/A	N/A	1.22
83-503-01	1/2"	.62	1.69	3.38	2.00	4.81	N/A	N/A	1.90
83-504-01A	3/4"	.81	1.93	3.87	2.18	4.81	1.25	1/4-20	2.56
83-505-01A	1"	1.00	2.25	4.50	2.62	5.50	1.62	5/16-18	3.78
83-506-01A	1-1/4"	1.25	2.43	4.87	2.87	5.50	1.62	5/16-18	5.24
83-507-01A	1-1/2"	1.50	2.62	5.25	3.35	8.00	1.62	5/16-18	7.67
83-508-01A	2"	2.00	3.12	6.25	3.75	8.00	1.62	5/16-18	15.60

VARIATIONS AVAILABLE:

83-540 Series (316 SS Ball & Stem)

OPTIONS AVAILABLE:

(SUFFIX)	OPTION	SIZES
-02-	Static Grounded	1/4" to 2"
-03-	1-1/4" Stem Extension	1/4" to 2"
-04-	2-1/4" Stem Extension	1/4" to 2"
-07-	Tee Handle	1/4" to 2"
-08-	90° Reversed Stem	1/4" to 2"
-10-	SS Lever & Nut	1/4" to 2"
-14-	Vented Ball (see page J-2)	1/4" to 2"
-16-	Vertical Chain Lever	1/2" to 2"
-18-	Plain Yellow Grip	1/4" to 2"
-27-	Latch Lock Lever	1/4" to 2"
-29-	Firesafe	1/4" to 2"
-32-	SS Tee Handle & Nut	1/4" to 2"
-38-	PEEK Seats & Bearing (Graphite Packing & Seals)	1/4" to 2"
-45-	Less Lever & Nut	1/4" to 2"
-47-	SS Latch-Lock Oval Handle	1/4" to 2"
-48-	SS Oval Handle (No Latch) & Nut	1/4" to 2"
-56-	Multifill Seats	1/4" to 2"
-58-	Chain Lever - Horizontal	1/2" to 2"
-59-	SS External Trim - 3-pc. Valves	1/4" to 2"
-60-	Grounded Ball & Stem	1/4" to 2"
-63-	Female Threaded x Socket Weld	1/4" to 2"
-64-	250# Steam Trim	1/4" to 2"
-P01-	BSPP (Parallel) Thread Connection	1/4" to 2"
-T01-	BSPT (Tapered) Thread Connection	1/4" to 2"

For Pressure/Temperature Ratings, Refer to Page M-12, Graph No. 11

Apollo® 83-600 Series

Carbon Steel 3-Piece High Pressure Full Port Socket Weld Ball Valve

Socket Weld, 1/2" to 1" 1500 psig WOG, 1-1/4" & 2" 1250 psig WOG, Cold Non-Shock. 150 psig Saturated Steam. Vacuum Service to 29 inches Hg.

Federal Specification: WW-V-35C, Type: II, Composition: CS, Style: 1.

MSS SP-110; Ball Valves Threaded, Socket-Welding, Solder Joint, Grooved and Flared Ends.

FEATURES

- Nitride corrosion protection
- Adjustable packing gland
- In-line repairable
- Blow-out-proof stem design
- (-29) Certified to API standard 607, 4th Edition, Class 600 burn
- Meets NACE MR-01-75 with SS trim
- Investment Cast Components
- Actuator mounting pad (3/4" to 2")
- RPTFE seats and seals

STANDARD MATERIAL LIST

1. Lever and grip	CS, zinc plated w/vinyl	8. Gland nut	A108-CS
2. Body bolt (4)	Steel, SAE grade 8 zinc plated	9. Stem	A108-CS
3. Hex nut (4)	Steel, SAE grade 8 zinc plated	10. Lever nut	Steel, zinc plated
4. Ball	A108-CS chrome plated	11. Stem packing	RPTFE
5. Seat (2)	RPTFE	12. Stem bearing	RPTFE
6. End cap (2)	A216-WCB	13. Body	A216-WCB
7. Seat holder (2)	A108-CS	14. Body seal (2)	RPTFE

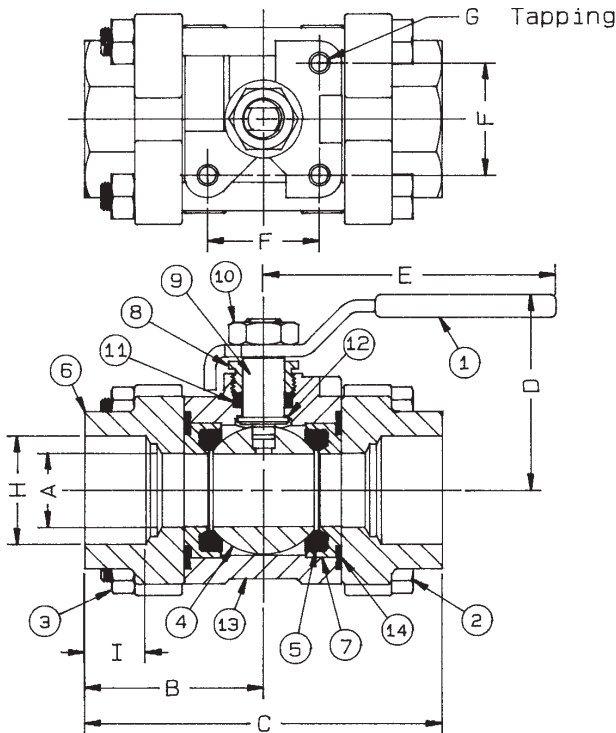

VARIATIONS AVAILABLE:

83-640 Series (316 SS Ball & Stem)

OPTIONS AVAILABLE:

(SUFFIX)	OPTION	SIZES
-02-	Static Grounded	1/2" to 2"
-03-	1-1/4" Stem Extension	1/2" to 2"
-04-	2-1/4" Stem Extension	1/2" to 2"
-07-	Tee Handle	1/2" to 2"
-08-	90° Reversed Stem	1/2" to 2"
-10-	SS Lever & Nut	1/2" to 2"
-14-	Vented Ball (see page J-2)	1/2" to 2"
-15-	Round Handle	1/2" to 2"
-16-	Vertical Chain Lever	1/2" to 2"
-18-	Plain Yellow Grip	1/2" to 2"
-27-	Latch Lock Lever	1/2" to 2"
-29-	Firesafe	1/2" to 2"
-32-	SS Tee Handle & Nut	1/2" to 2"
-38-	PEEK Seats & Bearing (Graphite Packing & Seals)	1/2" to 2"
-45-	Less Lever & Nut	1/2" to 2"
-47-	SS Latch-Lock Oval Handle	1/2" to 2"
-48-	SS Oval Handle (No Latch) & Nut	1/4" to 2"
-56-	Multifill Seats	1/2" to 2"
-58-	Chain Lever - Horizontal	1/2" to 2"
-59-	SS External Trim - 3-pc. Valves	1/2" to 2"
-60-	Grounded Ball & Stem	1/2" to 2"
-64-	250# Steam Trim	1/2" to 2"

**For Pressure/Temperature Ratings,
Refer to Page M-12, Graph No. 11**

CARBON STEEL 3-PIECE HIGH PRESSURE FULL PORT
SOCKET WELD BALL VALVE

NUMBER	SIZE	A	B	C	D	E	F	G	H	I	Wt.
83-603-01	1/2"	.62	1.69	3.38	2.00	4.81	N/A	N/A	.855	.43	1.90
83-604-01A	3/4"	.81	1.93	3.87	2.18	4.81	1.25	1/4-20	1.065	.56	2.56
83-605-01A	1"	1.00	2.25	4.50	2.62	5.50	1.62	5/16-18	1.330	.68	3.78
83-606-01A	1-1/4"	1.25	2.43	4.87	2.87	5.50	1.62	5/16-18	1.675	.81	5.24
83-607-01A	1-1/2"	1.50	2.62	5.25	3.35	8.00	1.62	5/16-18	1.915	.87	7.67
83-608-01A	2"	2.00	3.12	6.25	3.75	8.00	1.62	5/16-18	2.406	1.06	15.60

Apollo® 85-100 Series Stainless Steel 3-Piece Ball Valve

Standard Port Threaded, 1000 psig WOG, Cold Non-Shock. 150 psig Saturated Steam.
Vacuum Service to 29 inches Hg.

Federal Specification: WW-V-35C, Type: II, Composition: SS, Style: 1.

MSS SP-110; Ball Valves Threaded, Socket-Welding, Solder Joint, Grooved and Flared Ends.

FEATURES

- Meets NACE MR-01-75
- Blow-out-proof stem design
- In-line repairable
- Investment cast components
- RPTFE seats and seals
- Adjustable packing gland

STANDARD MATERIAL LIST

1. Lever and grip	304 SS w/vinyl	7. Gland nut	A276-316
2. Stem packing	RPTFE	8. Stem	A276-316
3. Stem bearing	RPTFE	9. Lever nut	18-8 SS
4. Ball	A276-316	10. Body bolt (4)	18-8 SS
5. Seat (2)	RPTFE	11. Hex nut (4)	18-8 SS
6. End cap (2)	A351-CF3M	12. Body	A351-CF8M

OPTIONS AVAILABLE:

(SUFFIX)	OPTION	SIZES
-02-	Static Grounded	1/2"
-03-	1-1/4" Stem Extension	1/2"
-04-	2-1/4" Stem Extension	1/2"
-07-	Tee Handle	1/2"
-08-	90° Reversed Stem	1/2"
-14-	Vented Ball (see page J-2)	1/2"
-15-	Round Handle	1/2"
-18-	Plain Yellow Grip	1/2"
-24-	Graphite Stem Packing	1/2"
-27-	Latch Lock Lever	1/2"
-32-	SS Tee Handle & Nut	1/2"
-35-	VTFE Trim	1/2"
-45-	Less Lever & Nut	1/2"
-47-	SS Latch-Lock Oval Handle	1/2"
-48-	SS Oval Handle (No Latch) & Nut	1/2"
-49-	Assembled Dry	1/2"
-50-	2-1/4" CS Locking Stem Extension	1/2"
-57-	Oxygen Cleaned	1/2"
-60-	Grounded Ball & Stem	1/2"
-61-	Grounded Ball & Stem and Assembled Dry	1/2"
-63-	Threaded x Socket Weld	1/2"
-P01-	BSPP (Parallel) Thread Connection	1/2"
-T01-	BSPT (Tapered) Thread Connection	1/2"

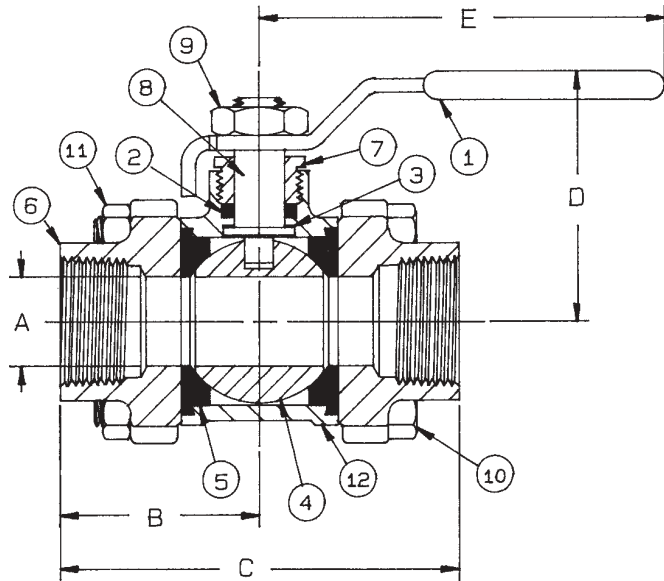

STAINLESS STEEL 3-PIECE BALL VALVE

NUMBER	SIZE	A	B	C	D	E	F	G	Wt.
85-101-01	1/4"	.43	1.28	2.56	1.81	3.87	N/A	N/A	1.02
85-102-01	3/8"	.50	1.28	2.56	1.81	3.87	N/A	N/A	.98
85-103-01	1/2"	.50	1.28	2.56	1.81	3.87	N/A	N/A	.97

**For Pressure/Temperature Ratings,
Refer to Page M-10, Graph No. 8**

Stainless Steel 3-Piece Socket Weld Ball Valve

Standard Port Socket Weld, 1000 psig WOG, Cold Non-Shock. 150 psig Saturated Steam.
Vacuum Service to 29 inches Hg.

Federal Specification: WW-V-35C, Type: II, Composition: SS, Style: 1.

MSS SP-110; Ball Valves Threaded, Socket-Welding, Solder Joint, Grooved and Flared Ends.

FEATURES

- Meets NACE MR-01-75
- Blow-out-proof stem design
- In-line repairable
- Investment cast components
- RPTFE seats and seals
- Adjustable packing gland

STANDARD MATERIAL LIST

1. Lever and grip	304 SS w/vinyl	7. Gland nut	A276-316
2. Stem packing	RPTFE	8. Stem	A276-316
3. Stem bearing	RPTFE	9. Lever nut	18-8 SS
4. Ball	A276-316	10. Body bolt (4)	18-8 SS
5. Seat (2)	RPTFE	11. Hex nut (4)	18-8 SS
6. End cap (2)	A351-CF3M	12. Body	A351-CF8M

OPTIONS AVAILABLE:

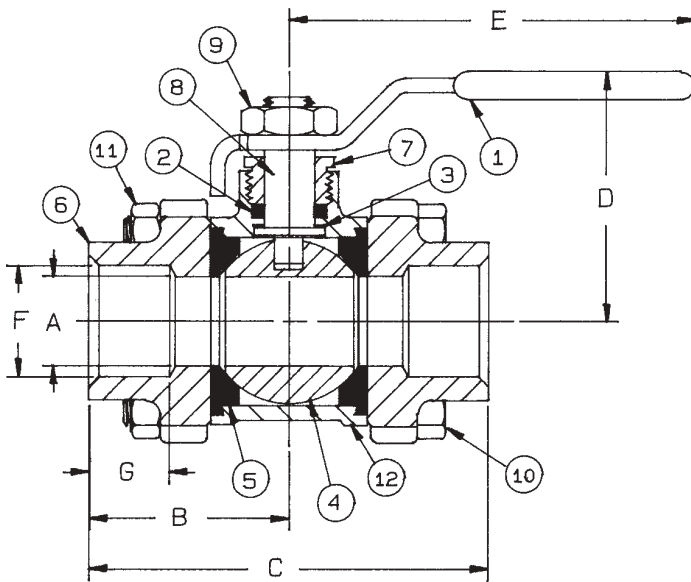

(SUFFIX)	OPTION	SIZES
-02-	Static Grounded	1/2"
-03-	1-1/4" Stem Extension	1/2"
-04-	2-1/4" Stem Extension	1/2"
-07-	Tee Handle	1/2"
-08-	90° Reversed Stem	1/2"
-14-	Vented Ball (see page J-2)	1/2"
-15-	Round Handle	1/2"
-18-	Plain Yellow Grip	1/2"
-24-	Graphite Stem Packing	1/2"
-27-	Latch Lock Lever	1/2"
-32-	SS Tee Handle & Nut	1/2"
-35-	VTFE Trim	1/2"
-45-	Less Lever & Nut	1/2"
-47-	SS Latch-Lock Oval Handle	1/2"
-48-	SS Oval Handle (No Latch) & Nut	1/2"
-49-	Assembled Dry	1/2"
-57-	Oxygen Cleaned	1/2"
-60-	Grounded Ball & Stem	1/2"

**For Pressure/Temperature Ratings,
Refer to Page M-10, Graph No. 8**

STAINLESS STEEL 3-PIECE SOCKET WELD BALL VALVE

NUMBER	SIZE	A	B	C	D	E	F	G	H	I	Wt.
85-203-01	1/2"	.50	1.28	2.56	1.81	3.87	N/A	N/A	.855	.43	.97

Stainless Steel 3-Piece High Pressure Full Port Ball Valve

Threaded, 1/4" to 1" 1500 psig WOG, 1-1/4" & 2" 1250 psig WOG, Cold Non-Shock. 150 psig Saturated Steam. Vacuum Service to 29 inches Hg.

Federal Specification: WW-V-35C, Type: II, Composition: SS, Style: 1.

MSS SP-110; Ball Valves Threaded, Socket-Welding, Solder Joint, Grooved and Flared Ends.

FEATURES

- Adjustable packing gland
- In-line repairable
- Blow-out-proof stem design
- (-29) Certified to API standard 607, 4th Edition, Class 600 burn
- Meets NACE MR-01-75
- Investment Cast Components
- Actuator mounting pad (3/4" to 2")
- RPTFE seats and seals

STANDARD MATERIAL LIST

1. Lever and grip	304 SS w/vinyl	8. Gland nut	A276-316
2. Stem packing	RPTFE	9. Stem	A276-316
3. Stem bearing	RPTFE	10. Lever nut	304 SS
4. Ball	A276-316	11. Body bolt (4)	18-8 SS
5. Seat (2)	RPTFE	12. Hex nut (4)	18-8 SS
6. End cap (2)	A351-CF3M	13. Body	A351-CF8M
7. Seat holder (2)	A276-316	14. Body seal (2)	RPTFE

OPTIONS AVAILABLE:

(SUFFIX)	OPTION	SIZES
-02-	Static Grounded	1/4" to 2"
-03-	1-1/4" Stem Extension	1/4" to 2"
-04-	2-1/4" Stem Extension	1/4" to 2"
-07-	Tee Handle	1/4" to 2"
-08-	90° Reversed Stem	1/4" to 2"
-14-	Vented Ball (see page J-2)	1/4" to 2"
-15-	Round Handle	1/4" to 2"
-16-	Vertical Chain Lever	1/2" to 2"
-18-	Plain Yellow Grip	1/4" to 2"
-27-	Latch Lock Lever	1/4" to 2"
-29-	Firesafe	1/4" to 2"
-32-	SS Tee Handle & Nut	1/4" to 2"
-38-	PEEK Seats & Bearing (Graphite Packing & Seals)	1/4" to 2"
-45-	Less Lever & Nut	1/4" to 2"
-47-	SS Latch-Lock Oval Handle	1/4" to 2"
-48-	SS Oval Handle (No Latch) & Nut	1/4" to 2"
-49-	Assembled Dry	1/4" to 2"
-56-	Multifull Seats	1/4" to 2"
-57-	Oxygen Cleaned	1/4" to 2"
-58-	Chain Lever - Horizontal	1/2" to 2"
-60-	Grounded Ball & Stem	1/4" to 2"
-63-	Threaded x Socket Weld	1/2" to 2"
-64-	250# Steam Trim	1/4" to 2"
-66-	FNPT x Butt Weld	1/2" to 2"
-P01-	BSPP (Parallel) Thread Connection	1/4" to 2"
-T01-	BSPT (Tapered) Thread Connection	1/4" to 2"

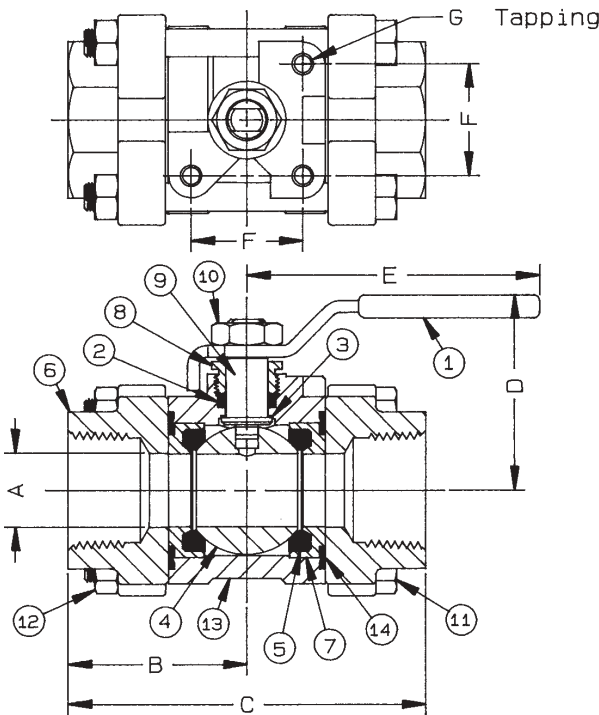

STAINLESS STEEL 3-PIECE HIGH PRESSURE FULL PORT BALL VALVE

NUMBER	SIZE	A	B	C	D	E	F	G	Wt.
86-501-01	1/4"	.43	1.50	3.00	1.93	3.87	N/A	N/A	1.23
86-502-01	3/8"	.50	1.50	3.00	1.93	3.87	N/A	N/A	1.18
86-503-01	1/2"	.62	1.69	3.38	2.00	4.81	N/A	N/A	1.62
86-504-01A	3/4"	.81	1.93	3.87	2.18	4.81	1.25	1/4-20	2.27
86-505-01A	1"	1.00	2.25	4.50	2.62	5.50	1.62	5/16-18	3.54
86-506-01A	1-1/4"	1.25	2.43	4.87	2.87	5.50	1.62	5/16-18	6.00
86-507-01A	1-1/2"	1.50	2.62	5.25	3.35	8.00	1.62	5/16-18	8.84
86-508-01A	2"	2.00	3.12	6.25	3.75	8.00	1.62	5/16-18	15.28

For Pressure/Temperature Ratings, Refer to Page M-11, Graph No. 12

Stainless Steel 3-Piece High Pressure Full Port Socket Weld Ball Valve

Socket Weld, 1/2" to 1" 1500 psig WOG, 1-1/4" & 2" 1250 psig WOG, Cold Non-Shock. 150 psig Saturated Steam.

Vacuum Service to 29 inches Hg.

Federal Specification: WW-V-35C, Type: II, Composition: SS, Style: 1.

MSS SP-110; Ball Valves Threaded, Socket-Welding, Solder Joint, Grooved and Flared Ends.

FEATURES

- Adjustable packing gland
- In-line repairable
- Blow-out-proof stem design
- (-29) certified to API 607 4TH ed. Class 600 burn
- Meets NACE MR-01-75
- Investment Cast Components
- Actuator mounting pad (3/4" to 2")
- RPTFE seats and seals

STANDARD MATERIAL LIST

1. Lever and grip	304 SS w/vinyl	8. Gland nut	A276-316
2. Stem packing	RPTFE	9. Stem	A276-316
3. Stem bearing	RPTFE	10. Lever nut	18-8 SS
4. Ball	A276-316	11. Body bolt (4)	18-8 SS
5. Seat (2)	RPTFE	12. Hex nut (4)	18-8 SS
6. End cap (2)	A351-CF3M	13. Body	A351-CF8M
7. Seat holder (2)	A276-316	14. Body seal (2)	RPTFE

OPTIONS AVAILABLE:

(SUFFIX)	OPTION	SIZES
-02-	Static Grounded	1/2" to 2"
-03-	1-1/4" Stem Extension	1/2" to 2"
-04-	2-1/4" Stem Extension	1/2" to 2"
-07-	Tee Handle	1/2" to 2"
-08-	90° Reversed Stem	1/2" to 2"
-14-	Vented Ball (see page J-2)	1/2" to 2"
-15-	Round Handle	1/2" to 2"
-16-	Vertical Chain Lever	1/2" to 2"
-18-	Plain Yellow Grip	1/2" to 2"
-27-	Latch Lock Lever	1/2" to 2"
-29-	Firesafe	1/2" to 2"
-32-	SS Tee Handle & Nut	1/2" to 2"
-38-	PEEK Seats & Bearing (Graphite Packing & Seals)	1/2" to 2"
-45-	Less Lever & Nut	1/2" to 2"
-48-	SS Oval Handle (No Latch) & Nut	1/2" to 2"
-49-	Assembled Dry	1/2" to 2"
-56-	Multifill Seats	1/2" to 2"
-57-	Oxygen Cleaned	1/2" to 2"
-58-	Chain Lever - Horizontal	1/2" to 2"
-60-	Grounded Ball & Stem	1/2" to 2"
-64-	250# Steam Trim	1/2" to 2"

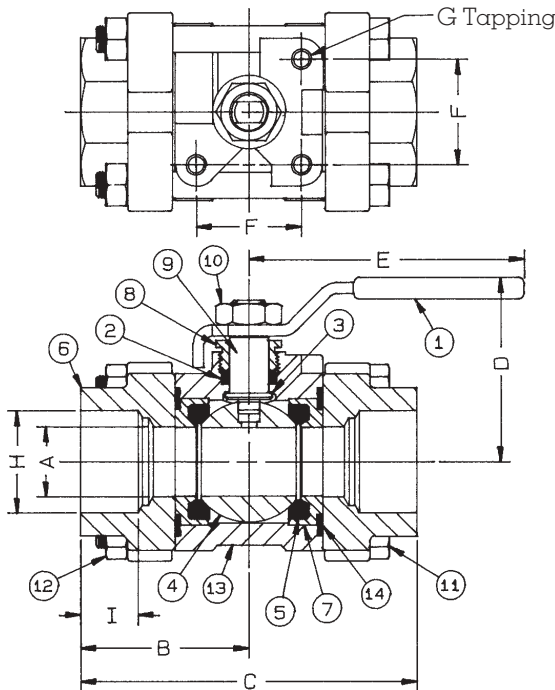

STAINLESS STEEL 3-PIECE HIGH PRESSURE
FULL PORT SOCKET WELD BALL VALVE

NUMBER	SIZE	A	B	C	D	E	F	G	H	I	Wt.
86-603-01	1/2"	.62	1.69	3.38	2.00	4.81	N/A	N/A	.855	.43	1.60
86-604-01A	3/4"	.81	1.93	3.87	2.18	4.81	1.25	1/4-20	1.065	.56	2.24
86-605-01A	1"	1.00	2.25	4.50	2.62	5.50	1.62	5/16-18	1.330	.68	3.32
86-606-01A	1-1/4"	1.25	2.43	4.87	2.87	5.50	1.62	5/16-18	1.675	.81	5.85
86-607-01A	1-1/2"	1.50	2.62	5.25	3.35	8.00	1.62	5/16-18	1.915	.87	8.62
86-608-01A	2"	2.00	3.12	6.25	3.75	8.00	1.62	5/16-18	2.406	1.06	15.60

**For Pressure/Temperature Ratings,
Refer to Page M-11, Graph No. 12**

Stainless Steel 3-Piece High Pressure Full Port Butt-Weld Ball Valve

Schedule 10 Butt-Weld, 1/2" to 1" 1500 psig WOG, 1-1/2" & 2" 1250 psig WOG, Cold Non-Shock. 150 psig Saturated Steam.

Vacuum Service to 29 inches Hg.

Federal Specification: WW-V-35C, Type: II, Composition: SS, Style: 1.

MSS SP-110; Ball Valves Threaded, Socket-Welding, Solder Joint, Grooved and Flared Ends.

MSS SP-72; Ball Valves with Flanged or Buttweld Ends for General Service.

FEATURES

- Adjustable packing gland
- In-line repairable
- Blow-out-proof stem design
- (-29) Certified to API standard 607, 4th Edition, Class 600 burn
- Meets NACE MR-01-75
- Investment Cast Components
- Actuator mounting pad (3/4" to 2")
- RPTFE seats and seals

STANDARD MATERIAL LIST

1. Lever and grip	304 SS w/vinyl	8. Gland nut	A276-316
2. Stem packing	RPTFE	9. Stem	A276-316
3. Stem bearing	RPTFE	10. Lever nut	304 SS
4. Ball	A276-316	11. Body bolt (4)	18-8 SS
5. Seat (2)	RPTFE	12. Hex nut (4)	18-8 SS
6. End cap (2)	A351-CF3M	13. Body	A351-CF8M
7. Seat Holder (2)	A276-316	14. Body seal (2)	RPTFE

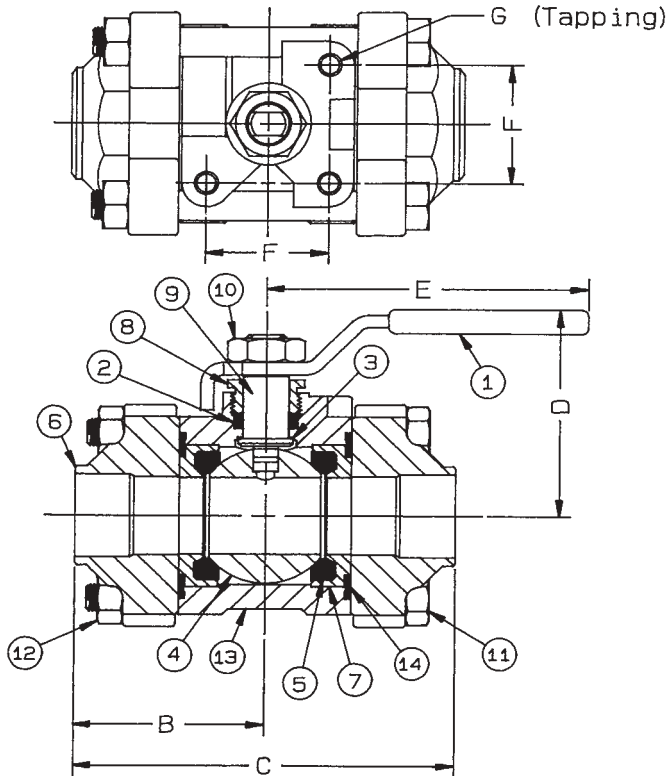

STAINLESS STEEL 3-PIECE HIGH PRESSURE FULL PORT BUTT-WELD BALL VALVE

NUMBER	SIZE	A	B	C	D	E	F	G	Wt.
86-903-01	1/2"	.62	1.69	3.38	2.00	4.81	N/A	N/A	1.60
86-904-01A	3/4"	.81	1.93	3.87	2.18	4.81	1.25	1/4-20	2.24
86-905-01A	1"	1.00	2.25	4.50	2.62	5.50	1.62	5/16-18	3.32
86-907-01A	1-1/2"	1.50	2.62	5.25	3.35	8.00	1.62	5/16-18	8.62
86-908-01A	2"	2.00	3.11	6.22	3.75	8.00	1.62	5/16-18	15.60

OPTIONS AVAILABLE:

(SUFFIX)	OPTION	SIZES
-02-	Static Grounded	1/2" to 2"
-03-	1-1/4" Stem Extension	1/2" to 2"
-04-	2-1/4" Stem Extension	1/2" to 2"
-07-	Tee Handle	1/2" to 2"
-08-	90° Reversed Stem	1/2" to 2"
-14-	Vented Ball (see page J-2)	1/2" to 2"
-15-	Round Handle	1/2" to 2"
-16-	Vertical Chain Lever	1/2" to 2"
-18-	Plain Yellow Grip	1/2" to 2"
-27-	Latch Lock Lever	1/2" to 2"
-29-	Firesafe	1/2" to 2"
-32-	SS Tee Handle & Nut	1/2" to 2"
-35-	VITE Trim	1/2" to 2"
-38-	PEEK Seats & Bearing (Graphite Packing & Seals)	1/2" to 2"
-45-	Less Lever & Nut	1/2" to 2"
-47-	SS Latch-Lock Oval Handle	1/2" to 2"
-48-	SS Oval Handle (No Latch) & Nut	1/2" to 2"
-49-	Assembled Dry	1/2" to 2"
-57-	Oxygen Cleaned	1/2" to 2"
-58-	Chain Lever - Horizontal	1/2" to 2"
-60-	Grounded Ball & Stem	1/2" to 2"
-64-	250# Steam Trim	1/2" to 2"

For Pressure/Temperature Ratings, Refer to Page M-11, Graph No. 12